



# Datacard CD800 User Manual



Unicard - Your ID System Specialist  
[www.unicard.com.au](http://www.unicard.com.au)  
[sales@unicard.com.au](mailto:sales@unicard.com.au)



## Datacard<sup>®</sup> CD800<sup>™</sup> Card Printer

*User's Guide*

January 2017

Part No. 527443-001, Rev. D

## Notice

Please do not attempt to operate or repair this equipment without adequate training. Any use, operation or repair you perform that is not in accordance with the information contained in this documentation is at your own risk.

## Trademark Acknowledgments

Datacard is a registered trademark and service mark of Entrust Datacard Corporation in the United States and other countries.

Entrust is a registered trademark and service mark in the United States and other countries.

MasterCard is a registered trademark of MasterCard International Incorporated.

Visa is a registered trademark of Visa International Service Association.

All other product names are the property of their respective owners.

## Proprietary Notice

The design and information contained in these materials are protected by US and international copyright laws.

All drawings and information herein are the property of Entrust Datacard Corporation. All unauthorized use and reproduction is prohibited.

### **Entrust Datacard**

1187 Park Place

Shakopee, MN 55379

Phone: 952-933-1223

Fax: 952-933-7971

[www.entrustdatacard.com](http://www.entrustdatacard.com)

Copyright © 2014–2017 Entrust Datacard Corporation. All rights reserved.

# Compliance Statements

## Liability

The WARNING and CAUTION labels have been placed on the equipment for your safety. Please do not attempt to operate or repair this equipment without adequate training. Any use, operation, or repair in contravention of this document is at your own risk.

## Safety

The following basic safety tips are given to ensure safe installation, operation, and maintenance of Entrust Datacard™ equipment.

- Connect equipment to a grounded power source. Do not defeat or bypass the ground lead.
- Place the equipment on a stable surface (table) and ensure floors in the work area are dry and non-slip.
- Know the location of equipment branch circuit interrupters or circuit breakers and how to turn them on and off in case of emergency.
- Know the location of fire extinguishers and how to use them. ABC type extinguishers may be used on electrical fires.
- Know local procedures for first aid and emergency assistance at the customer facility.
- Use adequate lighting at the equipment location.
- Maintain the recommended temperature and humidity range in the equipment area.

# Regulatory Compliance

## EMC Compliance Notice

To ensure compliance of the model RX10 retransfer printer to the radiated emissions requirements for class "A" Information Technology Equipment, be sure to use a shielded Ethernet cable when connecting to your network

## Notice for USA (FCC Notice)

This equipment has been tested and found to comply with the limits for Class A computing devices, pursuant to Part 15 of FCC rules. These limits are designed to provide reasonable protection against harmful interference when the equipment is operated in a commercial environment. This equipment generates, uses, and can radiate radio frequency energy. If this equipment is not installed and used in accordance with this instruction manual, it may cause harmful interference to radio communications. Operation of this equipment in a residential area is likely to cause harmful interference in which case the user will be required to correct the interference at their own expense. Changes or modifications not expressly approved by the party responsible for compliance could void the user's authority to operate the equipment.

This device complies with Part 15 of the FCC Rules. Operation is subject to the following two conditions: (1) This device may not cause harmful interference, and (2) this device must accept any interference received, including interference that may cause undesired operation.

## Notice for Canada

### Industry Canada

This digital apparatus does not exceed the Class A limits for radio noise for digital apparatus set out in the Radio Interference Regulations of the Canadian Department of Communications.

Le présent appareil numérique n'émet pas de bruits radioélectriques dépassant les limites applicables aux appareils numériques de la classe A prescrites dans le Règlement sur le brouillage radioélectrique édicté par le ministère des Communications du Canada.

### **RSS-Gen, Issue 3, December 2010, Section 7.1.3 User Manual Notice**

This Device complies with Industry Canada License-exempt RSS standard(s). Operation is subject to the following two conditions: 1) this device may not cause interference, and 2) this device must accept any interference, including interference that may cause undesired operation of the device.

Cet appareil est conforme avec Industrie Canada RSS standard exemptes de licence(s). Son fonctionnement est soumis aux deux conditions suivantes: 1) ce dispositif ne peut causer des interférences, et 2) cet appareil doit accepter toute interférence, y compris les interférences qui peuvent causer un mauvais fonctionnement du dispositif.

## Notice for Europe

The EU Declaration of Conformity can be found on [EntrustDatacard.com](http://EntrustDatacard.com)

**WARNING:** This is a class A product. This equipment is compliant with class A of either CISPR32 or CISPR22. In a domestic/residential environment this equipment may cause radio interference, in which case the user may be required to take adequate measures.

WEEE: The model RX10 retransfer printer uses a lithium coin cell battery. Refer to the service manual for battery removal instructions.

## Notice for Australia

This is a Class A product. In a domestic environment this product may cause radio interference, in which case the user may be required to take adequate measures.

## Notice for China (Simplified Chinese)

### 警告

此为 A 级产品，在生活环境中，该产品可能会造成无线电干扰。在这种情况下，可能需要用户对干扰采取切实可行的措施。

## Notice for Taiwan (Traditional Chinese)

警告使用者：  
這是甲類的資訊產品，在居住的環境中使用時，可能會造成射頻干擾，在這種情況下，使用者會被要求採用某些適當的對策。

## Notice for Japan

### Japanese Voluntary Control Council for Interference (VCCI) class A statement

この装置は、クラス A 情報技術装置です。この装置を家庭環境で使用すると電波妨害を引き起こすことがあります。この場合には使用者が適切な対策を講ずるよう要求されることがあります。

VCCI-A

## Korea Communications Commission (KCC) statement

이 기기는 업무용(A급)으로 전자파적합기기로서 판매자 또는 사용자는 이 점을 주의하시기 바라며, 가정외의 지역에서 사용하는 것을 목적으로 합니다.

## California Proposition 65 Compliance

**WARNING:** This product contains chemicals, including lead, known to the State of California to cause cancer, and birth defects or other reproductive harm. *Wash hands after handling.*

Entrust Datacard believes that its products are not harmful when used as designed. However, the above warning is made in compliance with the State of California Safe Drinking Water and Toxic Enforcement Act of 1986, which requires warning labels on products that may contain elements that the State of California considers harmful.

## California Lithium Perchlorate Warning

Perchlorate Material - special handling may apply. See [www.dtsc.ca.gov/hazardouswaste/perchlorate](http://www.dtsc.ca.gov/hazardouswaste/perchlorate).

This notice is required by California Code of Regulations, Title 22, Division 4.5, Chapter 33: Best Management Practices for Perchlorate Materials. This product/part includes a battery that contains Perchlorate material.

## Revision Log

### CD800 Card Printer User's Guide

Revision	Date	Description of Changes
A	March 2014	First release of this document (formerly Part No. 527248-001). Updated for CLM laminator and XPS Card Printer Driver 5.0.
B	February 2015	Updated for XPS Card Printer Driver 6.0; added IPv6 information.
C	November 2015	Updated for XPS Card Printer Driver 6.2 and new printer firmware functionality.
D	January 2017	General updates.





# Contents

<b>Chapter 1: Introduction</b> .....	<b>1</b>
<b>About this Manual</b> .....	<b>1</b>
<b>Intended Audience</b> .....	<b>1</b>
<b>Technical Support</b> .....	<b>1</b>
<b>Chapter 2: About the Printer</b> .....	<b>3</b>
<b>About the CD800 Card Printer</b> .....	<b>3</b>
<b>Printer Components</b> .....	<b>3</b>
Printer Left Side .....	4
Printer Right Side .....	5
Printer with Single Input Hopper .....	6
Printer with Optional Multi-Hopper .....	7
Print Ribbon Cartridge .....	8
Printer with Optional CLM Laminator .....	9
System Label .....	9
<b>Chapter 3: Using the System</b> .....	<b>11</b>
<b>How the Card Travels</b> .....	<b>11</b>
<b>Card Printer System Overview</b> .....	<b>12</b>
Equipment .....	12
Tasks and Users .....	12
<b>Printer Controls</b> .....	<b>13</b>
Power Button .....	13
Down Arrow, Up Arrow, and Enter Key .....	13
User Button and Light .....	14
Ribbon Light .....	15
Card Light .....	15
LCD Panel Menus .....	16
<b>Retrieve the Printer's Network IP Address</b> .....	<b>18</b>
Retrieve an IPv4 Address .....	18
Retrieve an IPv6 Address .....	20
<b>Print a Test Card</b> .....	<b>22</b>
<b>Load and Replace Supplies</b> .....	<b>23</b>
Load Cards .....	23
Single Hopper .....	23
Optional Multi-Hopper .....	24
Use the Exception Slot .....	24
Load the Print Ribbon .....	25
Load the Cleaning Sleeve .....	26
Install the Ribbon Cartridge .....	26

<b>Chapter 4: Printing Cards</b> .....	<b>29</b>
<b>Before Starting to Print</b> .....	<b>29</b>
<b>Print Cards</b> .....	<b>30</b>
Print from ID Software .....	30
Print from Other Software .....	30
<b>Chapter 5: System Maintenance</b> .....	<b>33</b>
<b>Maintain the Printer</b> .....	<b>33</b>
<b>Clean the Printhead</b> .....	<b>34</b>
<b>Run a Cleaning Card</b> .....	<b>36</b>
Single Hopper .....	36
Optional Multi-Hopper .....	39
Prepare the Printer for Cleaning .....	39
Clean the Printer .....	40
Clean the Multi-Hopper Rollers .....	41
Prepare the Printer for Use .....	41
<b>Chapter 6: Troubleshooting</b> .....	<b>43</b>
<b>Locate a Problem Within the Card Production System</b> .....	<b>44</b>
<b>Locate a Problem with Basic Printer Functions</b> .....	<b>45</b>
<b>Installation Problems</b> .....	<b>46</b>
USB Installation Troubleshooting .....	47
Network Installation Troubleshooting .....	48
<b>Card Printer Driver Problems</b> .....	<b>48</b>
The Card Printer Driver does not detect the network-connected printer .....	49
The Card Printer Driver does not detect the USB-connected printer .....	49
Driver status or Windows print queue does not provide expected data .....	50
Printer Messages do not display on the PC .....	51
<b>Card Appearance</b> .....	<b>51</b>
Something did not print .....	52
Printing includes unexpected data .....	53
The color printing has flaws .....	53
The printing is too light .....	55
The printing is too dark .....	55
The monochrome printing has flaws .....	56
<b>Magnetic Stripe Problems</b> .....	<b>57</b>
<b>Laminator Problems</b> .....	<b>59</b>
Patch Appearance Problems .....	59
Topcoat Appearance Problems .....	61
<b>Use Advanced Troubleshooting Tools</b> .....	<b>63</b>
<b>Card Jams</b> .....	<b>64</b>
<b>Repair a Broken Ribbon</b> .....	<b>65</b>

<b>Messages and Conditions</b> .....	<b>65</b>
Messages on the Printer LCD .....	65
Printer Messages .....	66
Laminator Messages .....	67
Messages from the XPS Card Printer Driver on the PC .....	69
Messages from Printer Manager .....	69
Other Messages .....	69
Respond to Messages .....	70
Printer Messages .....	70
Close and lock doors .....	70
100: Request not supported .....	70
101: Job could not complete .....	70
102: Card not in position .....	71
103: Printer problem .....	71
104: Critical problem .....	71
105: Magstripe data error .....	71
106: Magstripe data not found .....	72
107: Magstripe read data error .....	72
108: Magstripe read no data .....	72
109: Print ribbon problem .....	73
110: Print ribbon out or missing .....	73
111: Card not picked .....	73
112: Card hopper empty .....	74
113: Close cover to continue .....	74
114: Cover opened during job .....	74
116: Magstripe not available .....	75
117: Reader not available .....	75
118: Print ribbon type problem .....	76
119: Print ribbon not supported .....	76
120: User paused the printer .....	76
121: Print ribbon not identified .....	76
122: Magstripe format problem .....	77
123: Insert new card side 1 up .....	77
124: Insert same card side 2 up .....	77
149: Option not installed .....	77
150: Print while unlocked .....	77
151: Failed to lock .....	78
152: Insert new card side 2 up .....	78
153: Insert same card side 2 up .....	78
170: Insert new card side 1 up .....	78
171: Insert same card side 1 up .....	78
172: Insert cleaning card .....	79
173: Improper shutdown .....	79
224: Supply region not valid .....	79
245: Configuration error .....	79

Laminator Messages . . . . .	80
177: Laminator not available . . . . .	80
196: Laminator error critical . . . . .	80
197: Laminator entry card problem. . . . .	80
198: L1 area card problem. . . . .	80
199: L2 area card problem. . . . .	81
200: Laminator exit card problem . . . . .	81
201: L1 supply problem . . . . .	81
202: L1 supply out or missing. . . . .	81
203: L1 supply type problem . . . . .	81
204: L1 supply not supported . . . . .	82
205: L1 supply not identified . . . . .	82
206: L2 supply problem . . . . .	82
207: L2 supply out or missing. . . . .	82
208: L2 supply type problem . . . . .	82
209: L2 supply not supported . . . . .	83
210: L2 supply not identified . . . . .	83
211: L1 heater problem . . . . .	83
212: L2 heater problem. . . . .	83
213: L1 heater sensor problem. . . . .	83
214: L2 heater sensor problem. . . . .	83
215: L1 heater roller problem . . . . .	84
216: L2 heater roller problem . . . . .	84
217: Debow problem . . . . .	84
218: Impresser problem. . . . .	84
219: Impresser sensor problem. . . . .	84
220: Impresser heater problem . . . . .	85
221: Bar code scanner problem . . . . .	85
222: Firmware version mismatch . . . . .	85
223: Laminator system mismatch. . . . .	85
Driver-Only Messages . . . . .	86
500: The printer is not available . . . . .	86
501: The printer connection was lost. . . . .	86
502: The card data is missing or is not usable. . . . .	86
504: The card data is missing or is not usable. . . . .	86
505: USB communication issue. . . . .	87
506: A card is currently processing . . . . .	87
507: The printer is unlocked . . . . .	87
508: The printer is shutting down . . . . .	87
509: The printer is offline or suspended . . . . .	87
510: The printer is unlocked . . . . .	87
Driver SDK Messages . . . . .	88
511: Cannot lock or unlock the printer. Locks are not installed. . . . .	88
512: Cannot lock or unlock the printer. The password is incorrect or invalid. . . . .	88
513: Cannot lock or unlock the printer. The printer is busy. . . . .	88

514: Cannot lock or unlock the printer. The cover is open. ....	88
515: Failed to lock or unlock the printer. The locks did not function. ....	88
516: Timeout expired before bar code could be read. ....	88
517: Wrong printer job ID. ....	88
<b>Appendix A: CLM Laminator</b> .....	<b>A-1</b>
<b>About the Laminator System</b> .....	<b>A-1</b>
Outside the Laminator .....	A-2
Laminator Back and Left Side .....	A-2
Laminator Status Light .....	A-3
Laminator Front and Right Side .....	A-3
Inside the Laminator .....	A-4
Laminator Configuration Label .....	A-5
<b>Laminator Setup</b> .....	<b>A-6</b>
Laminator Overlay Materials .....	A-6
Load Laminator Overlay Material .....	A-8
Card Design .....	A-10
Verify Setup .....	A-10
<b>Clear a Laminator Card Jam</b> .....	<b>A-11</b>
<b>Clean the Laminator</b> .....	<b>A-12</b>



# Chapter 1: Introduction



---

## About this Manual

This manual provides user information for the CD800™ card printer. The manual includes:

- An overview of printer components and options, and a description of the system label.
- How to use the printer, including how to power the printer on and off, how to use the front panel and LCD menus, card processing basics, how to print a test card, and how to load and replace supplies.
- How to perform routine maintenance and troubleshooting tasks.

An additional *Installation and Administrator's Guide* is available for use by administrators or other professionals responsible for setting up the printer to print cards. Refer to the *Owner's Library* CD.

## Intended Audience

The manual is intended for the printer operator who prints cards, loads and replaces supplies, maintains the printer, and performs troubleshooting.

## Technical Support

Use the following to contact Entrust Datacard Technical Phone Support.

Americas	+1 800.328.3996 or +1 952.988.2316
EMEA (Europe, Middle East, Africa)	+44 1489555627
Asia Pacific	+852 2821 0126





# Chapter 2: About the Printer

# 2

---

## About the CD800 Card Printer

The card printer applies images, text, and encoded data to plastic cards. It prints full-color and monochrome images, depending on the print ribbon installed.

A busy issuance site might issue several thousand cards a month. During busy times, the site might use more than one printer to keep up with demand. The printer issues cards either one at a time or in batches—up to 100 cards at a time. A 200-card input hopper is available and can be installed without tools. In addition, an optional multi-hopper with six input hoppers, each with a 100-card capacity, is available.

Other options available for the card printer include magnetic stripe and smart card modules. The configuration label on the printer shows the options installed. Refer to [“System Label” on page 9](#) for more information about recognizing the factory-installed options on your card printer. An optional laminator also is available when you purchase your printer or as a field upgrade (refer to [Appendix A: “CLM Laminator”](#).)

## Printer Components

Refer to the following to view the printer components and the different options:

- [Printer Left Side on page 4](#)
- [Printer Right Side on page 5](#)
- [Printer with Single Input Hopper on page 6](#)
- [Printer with Optional Multi-Hopper on page 7](#)
- [Print Ribbon Cartridge on page 8](#)
- [Printer with Optional CLM Laminator on page 9](#)
- [System Label on page 9](#)

# Printer Left Side

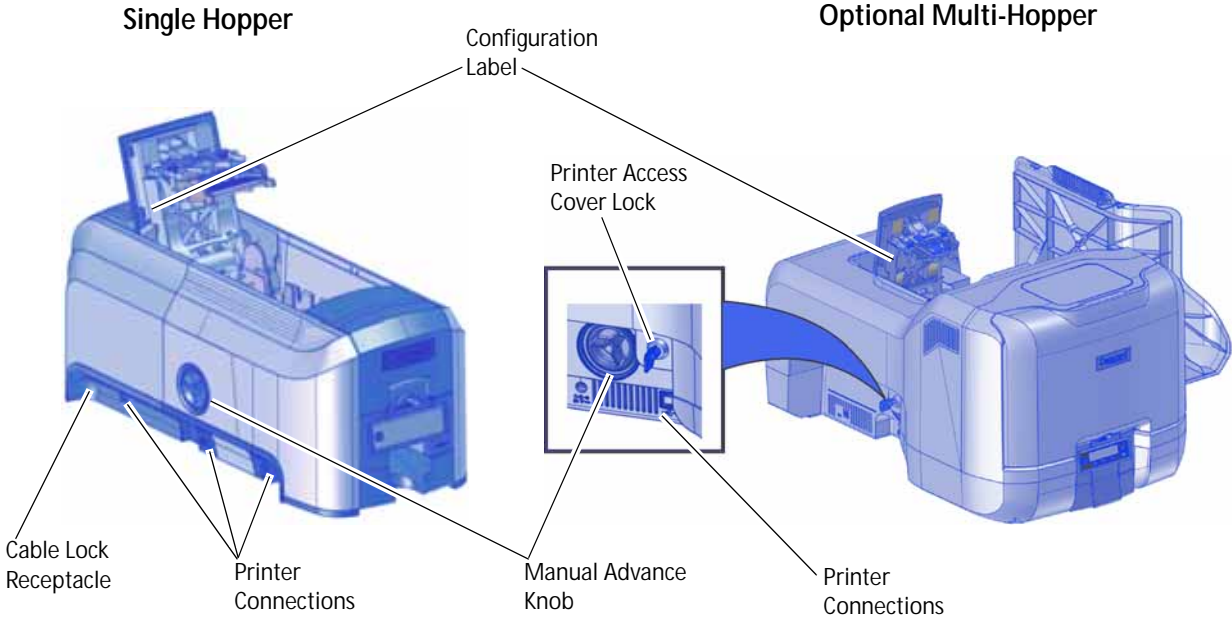

**Configuration Label** The label shows the location and date of manufacture, the printer serial number, and lists the options installed.

**Manual Advance Knob** The knob moves a card in the track to clear a card jam.

**Cable Lock Receptacle** The receptacle allows you to insert the security plate before attaching the optional cable lock.

**Printer Connections** Printer connections include:

- Power receptacle
- USB connection
- Network connection

**Printer Access Cover Lock** The lock provides secure access to the printer. A lock is available as an option on the CD800 single-hopper printer.

# Printer Right Side

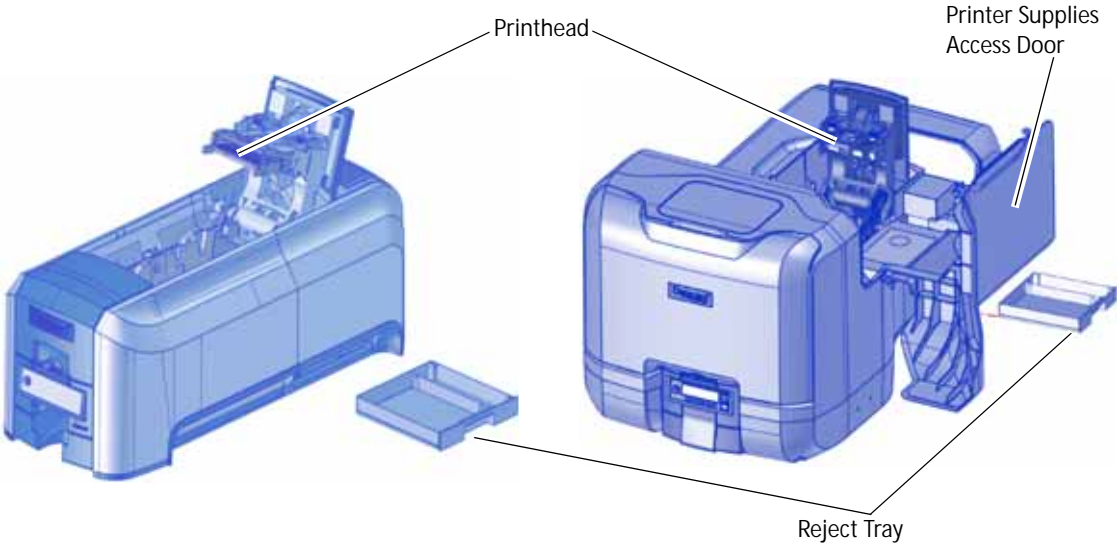

**Printhead**

The printhead transfers images to cards using the print ribbon.

**Printer Supplies Access Door**

The door provides access to the printhead and ribbon on a printer with the optional multi-hopper.

**Reject Tray**

Unfinished cards or cards not processed properly are placed in the reject tray.

# Printer with Single Input Hopper

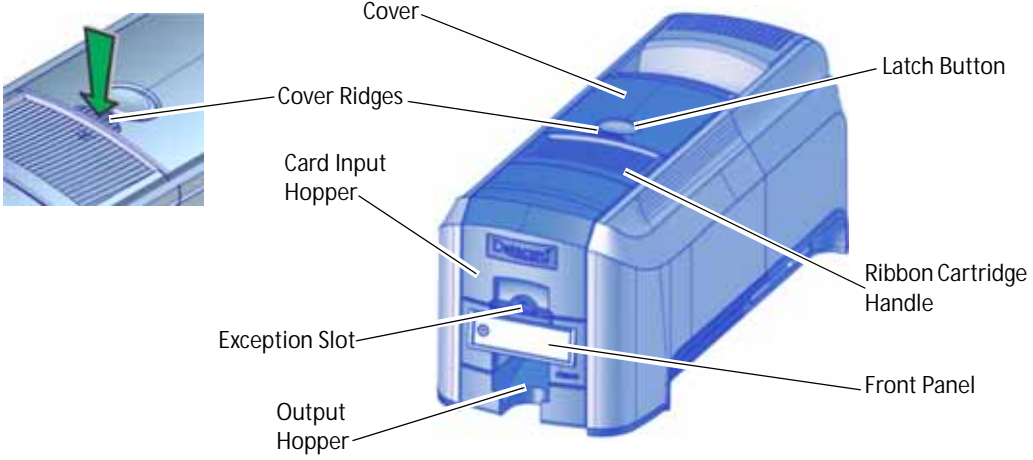

- Cover** Open the cover to access the printhead and ribbon.
- Latch Button** Push the latch button to release the cover and open the printer.
- Cover Ridges** Press down on the ridges when closing the cover to make sure that it latches completely on both sides.
- Ribbon Cartridge Handle** Use the handle to remove the print ribbon cartridge from the printer.
- Card Input Hopper** The input hopper loads cards to print. The hopper holds up to 100 cards (0.030 in. or 0.762 mm thickness).
- Exception Slot** The exception slot allows you to insert a single card into the printer.
- Front Panel** The front panel lets you work with the printer. It includes the USER button, the status lights, the power button, and the LCD panel with navigation keys.
- Output Hopper** The output hopper holds up to 25 completed cards.

## Printer with Optional Multi-Hopper

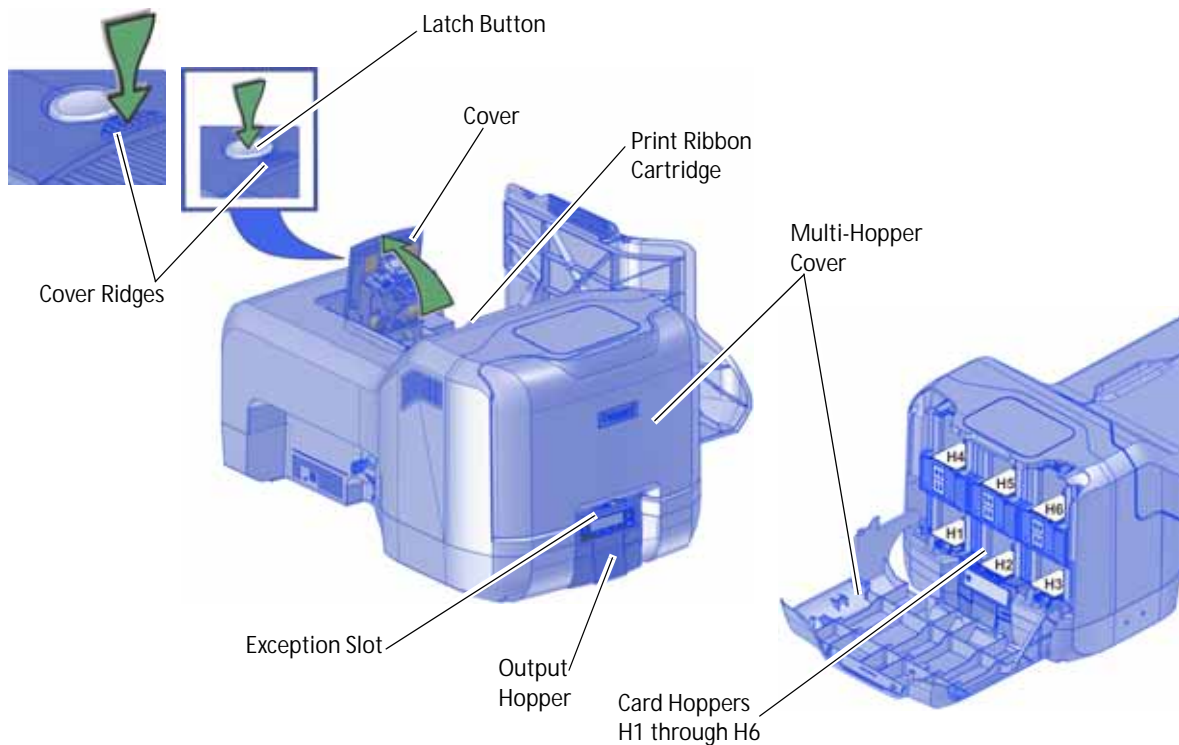

<b>Cover</b>	Open the cover to access the printhead and ribbon.
<b>Latch Button</b>	Push the latch button on top of the cover to release it and access the printhead and ribbon.
<b>Cover Ridges</b>	Press down on the ridges when closing the cover to make sure that it latches completely on both sides.
<b>Print Ribbon Cartridge</b>	The print ribbon cartridge is accessible when the cover is open. Use the cartridge handle to remove it from the printer.
<b>Multi-Hopper Cover</b>	Unlock the printer and open the multi-hopper cover to load card stock.
<b>Card Hoppers H1 through H6</b>	The H1 through H6 hoppers hold up to 100 cards each.
<b>Exception Slot</b>	The exception slot on a printer with the optional multi-hopper allows you to insert a single card directly into the printer at hopper 2.

# Print Ribbon Cartridge

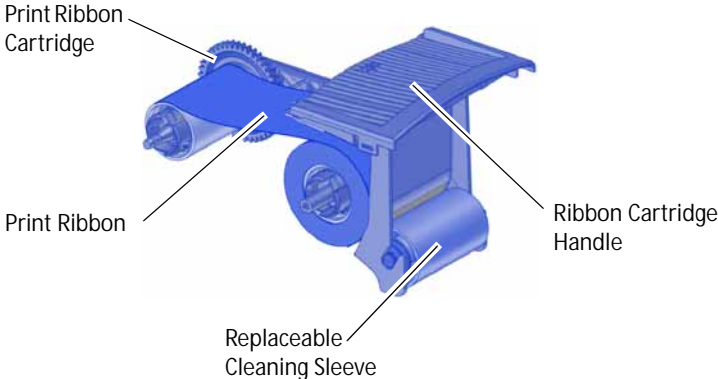

<b>Print Ribbon Cartridge</b>	The cartridge holds the ribbon for printing.
<b>Print Ribbon</b>	The ribbon applies images to cards.
<b>Replaceable Cleaning Sleeve</b>	The cleaning sleeve removes dust and other particles from cards to maintain print quality.
<b>Ribbon Cartridge Handle</b>	The handle allows you to remove and replace the ribbon cartridge in the printer.

## Printer with Optional CLM Laminator

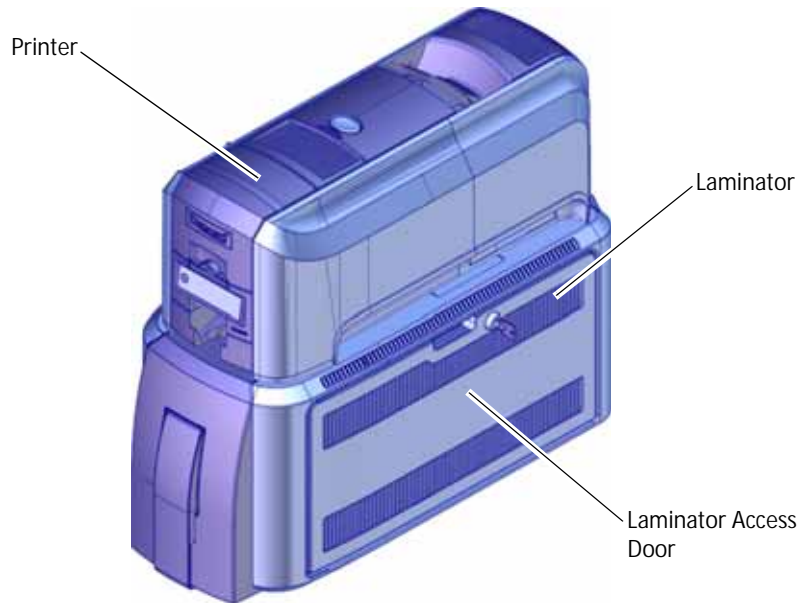

**Laminator**                      The optional laminator attaches to the printer and applies patch or topcoat overlay material to the card.

**Laminator Access Door**      Open the door to access the laminator cartridges.

Refer to [Appendix A: "CLM Laminator"](#) for complete information about using a laminating system.

## System Label

The printer configuration label on the side of the cover swingarm shows the components installed. It provides information that is useful when requesting service.

The label shows the following information:

- Printer model and serial number
- Configuration, which includes options installed in the printer
- Date and country of assembly
- MAC address to use when the printer is connected via an Ethernet network

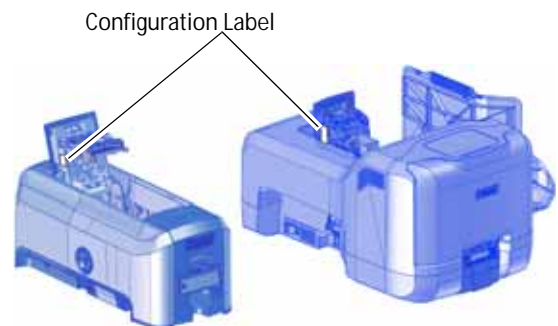

Additional labels may be attached to the printer to indicate components installed by the dealer or sales group after the printer was manufactured.





Option	Configuration Code
Input Hopper	H1=100 Card H3=Multi-Hopper
Magnetic Stripe	M1=ISO M2=JIS blank=no magnetic stripe option
Duplex	D1=Long Duplex blank=no duplex option
Smart Card	S $x$ =Smart Card option, where $x$ indicates the type of smart card reader installed blank=no smart card option
Lock	L2=Multi-Hopper Lock
Firmware Upgrade	F1=OpenCard enabled blank=no option



# Chapter 3: Using the System

# 3

This section provides information about how a card travels through the printer, printer controls, printing a test card, loading and replacing supplies, and cleaning the printer.

---

## How the Card Travels

Card processing begins when you send the card to print from the PC. The hopper pick mechanism picks a card and moves the card into the printer for processing.

Optionally, the card moves to the magnetic stripe encoding area or to the smart card park station, depending on the type of card selected. Encrypted data is decrypted and written to the card. If the system includes the CLM laminator, the card then moves into the laminator where the overlay material is applied to the card. The finished card exits the printer through the card output hopper.

# Card Printer System Overview

The card printer is used with other equipment and software to create a card production system. The system produces cards for a specific purpose, and the cards must meet requirements.

## Equipment

The system can include:

1. A PC, with software to support the printer, such as:
  - The XPS Card Printer Driver for Windows.
  - ID software designed specifically to capture, format, and save the data for cards.
  - A retail application such as Microsoft Word or Adobe Photoshop.
2. Capture devices, such as:
  - A digital camera connected to the PC to take photos for ID badges and other cards.
  - A signature capture pad, fingerprint reader, or PIN pad
3. The printer with supplies and a facility power source.
4. A data connection between the printer and PC, which can be a USB connection or a network connection. (You cannot use both with one printer.)

## Tasks and Users

Typical roles in a card production system include:

- The **operator**, who makes cards, loads supplies, and handles minor problems such as card jams.
- The **system administrator**, who sets up the card printer and other hardware, sets up card designs, configures card production software, and identifies the best use of the card printer in the organization.

# Printer Controls

The front panel of the printer provides the controls for operating the printer. The front panel controls are described in the following sections.

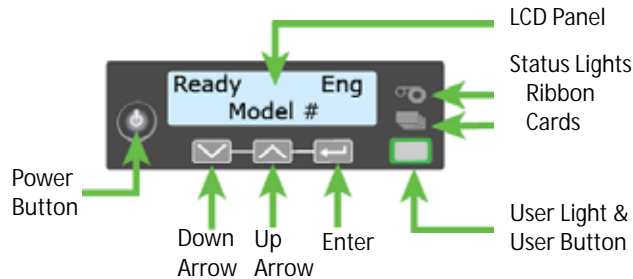

## Power Button

Use the POWER button to power off and power on the printer. All lights show steady amber while the printer powers on.

To power off the printer, press the button for 1 to 2 seconds until the printer begins to shut down.

To power off the printer while it is processing cards, press the button for 2 seconds or more. Card jobs in the printer are not completed.

## Down Arrow, Up Arrow, and Enter Key

Use the arrow keys to move through the printer menu system, and the ENTER key to make a selection.

Press the up or down arrow key while the LCD panel displays **Ready** to display additional information about the printer on line 2, including the firmware version, printer model, serial number, network IP address or USB IP address, ribbon part number, and region code, if available. If your system includes a laminator, the laminator firmware version and laminator serial number also display. If you don't press a key for 30 seconds, the LCD panel returns to the default **Ready** message.









When you use the arrow keys to view the printer IP address, only the IPv4 address displays. To see the IPv6 addresses available to the printer, you must use the LCD Status menu. Refer to [“Retrieve an IPv6 Address”](#) on page 20.

## User Button and Light



The printer's USER button displays with a border of light that indicates the system status. Use the USER button to:

- Suspend printer activity—press the USER button when the LCD panel displays **Ready**.
- Clear a message—press the USER button once.
- Clear all messages—press the USER button for 2 seconds or more.
- Clear all cards currently printing—press and hold the USER button for 2 seconds or more. (Make sure that this action is allowed in your card system.)
- Determine whether the printer is ready, busy printing, or not available. Indicators include the following. Refer to “[Messages and Conditions](#)” on [page 65](#) for a list of the LCD messages that correspond to the USER light.

Off	The printer is off or suspended.	
Green	The printer is ready.	
Blinking green	The printer is busy. OR There is an error in the laminator of a system that has the optional CLM laminator installed.	
Amber	The printer is not ready. The POWER button was pressed to turn off the printer.	
Blinking amber	The printer has an error.	
Color Cycle: Amber, Green, Light Green, Off	The printer is not ready or a door is open. The colors cycle quickly. <b>Close and Lock Doors</b> displays on the LCD panel if no other message is present.	



## Ribbon Light

The ribbon light indicates the status of the print ribbon in the printer. Indicators include the following. Refer to [“Messages and Conditions”](#) on [page 65](#) for a list of the LCD messages that correspond to the ribbon light.

Off	The print ribbon is okay.	
Blinking amber	A blinking light indicates one of the following: <ul style="list-style-type: none"><li>• The printer problem applies to the print ribbon.</li><li>• The print ribbon is low. The light blinks slowly (every 2 seconds).</li><li>• The print ribbon is out. The light blinks quickly (every 1/2 second).</li></ul>	
Blinking green	There is a problem with a laminator supply in a system with the optional CLM laminator.	

## Card Light

The card light indicates the status of cards in the printer. Indicators include the following. Refer to [“Messages and Conditions”](#) on [page 65](#) for a list of the LCD messages that correspond to the card light.

Off	Cards are okay.	
Blinking amber	A blinking light indicates either of the following: <ul style="list-style-type: none"><li>• No card is detected for the print job. Insert a card to continue printing.</li><li>• A scheduled printer cleaning is due. Insert a cleaning card now, or set aside time to run a cleaning card.</li></ul>	
Blinking green	There is a card problem in the laminator of a system with the optional CLM laminator.	

# LCD Panel Menus

The LCD panel shows the printer’s menu system and displays printer messages or conditions.

For a list of error messages and recovery information, refer to “Respond to Messages” on page 70.

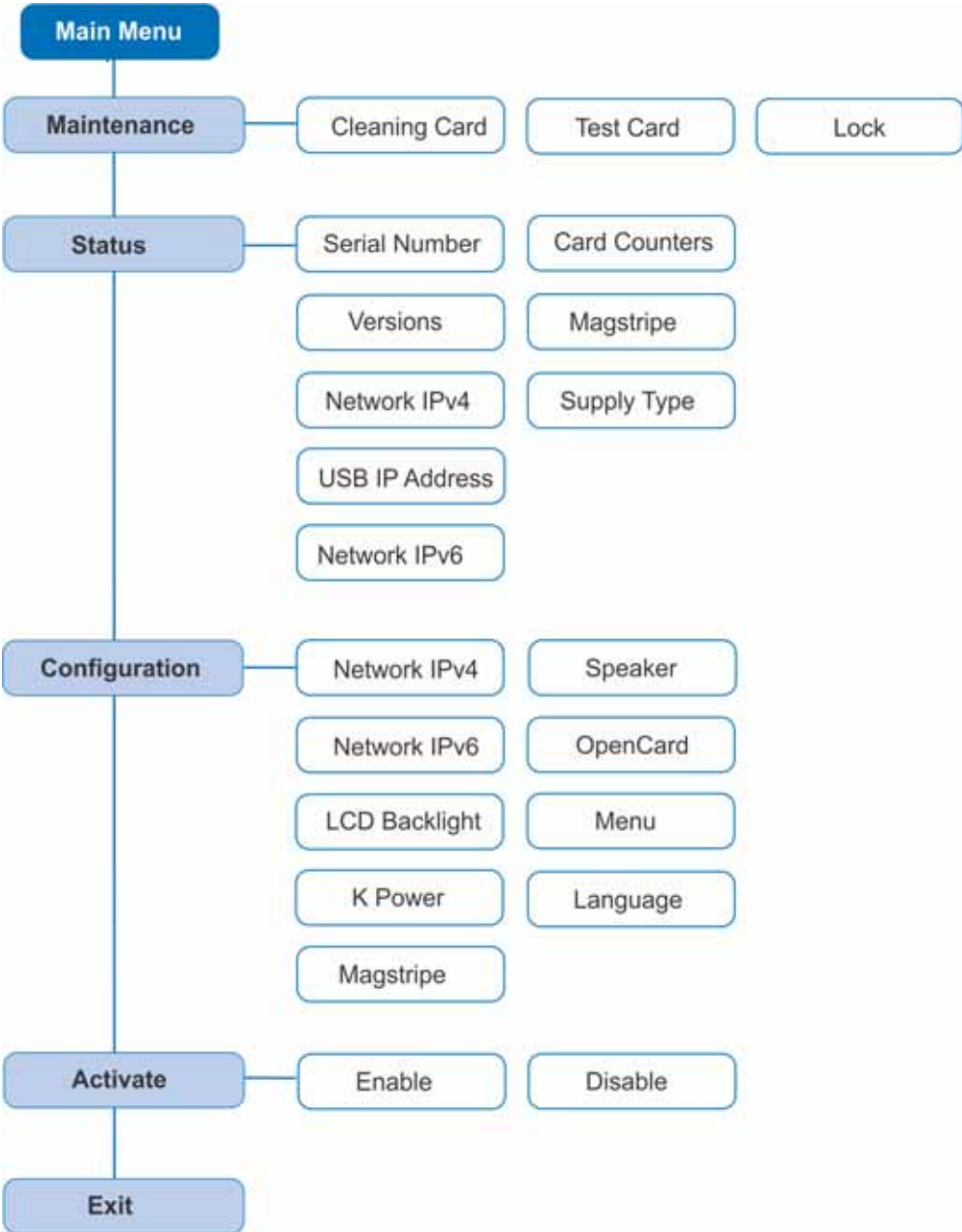

When the printer is in the **Ready** status, the LCD displays the model number of the printer. If a supply with a region code has been installed in the printer, the region code also displays on the **Ready** panel.



Printer without a region code



Printer with a region code

Press the **USER** button to suspend the printer. Then, press **ENTER** to enter the menu system. Use the arrow keys to move through the menus, and press **ENTER** to make a selection. The menu system has four major branches:

- Use the **Maintenance** menu to run a cleaning card, print a test card, or reset the locks on a system with locks.
- Use the **Status** menu to see settings and data about the printer.
- Use the **Configuration** menu to change settings.
- Use the **Activate** menu to enable or disable secure features of the printer.



Use the **Activate** menu only during installation or removal of financial systems that require activation.

#### HINTS & TIPS

- You can access the menu system when **Ready** displays on line 1 of the LCD panel.
- The printer returns to the **Ready** status after 2 minutes of no activity. Changes that have not been applied are lost.
- To leave a selection without changing the value, press the up or down arrow key until **Exit** displays, and then press **ENTER**.



# Retrieve the Printer's Network IP Address

You need to know the printer IP address to perform some tasks. For example, the XPS Card Printer Driver asks you to enter the network IP address during installation. You also use the IP address when launching Printer Manager, the printer's web interface, from a browser window.

To display the IP address, you can do one of the following:

- Press the up or down arrow key while the printer displays **Ready**. Refer to “[Down Arrow, Up Arrow, and Enter Key](#)” on [page 13](#).
- Use the LCD menu system Status menu.

The printer supports both IPv4 and IPv6 addressing. Because an IPv6 address is much longer than an IPv4 address, the LCD displays the two types of addresses differently.

## Retrieve an IPv4 Address

To display an IPv4 address using the Status menu, do the following. You also can display the subnet mask, gateway address, and MAC address, if necessary.

Begin with the printer power connected, and the printer connected to the network.

1. Press the POWER button (if needed) to power on the printer.
2. Access the **Status** menu in the LCD menu:
  - a. Press the USER button to suspend the printer.

- b. Press ENTER to enter the menu system.
- c. Press the down arrow to display **Status** on line 2.
- d. Press ENTER to enter the **Status** menu.

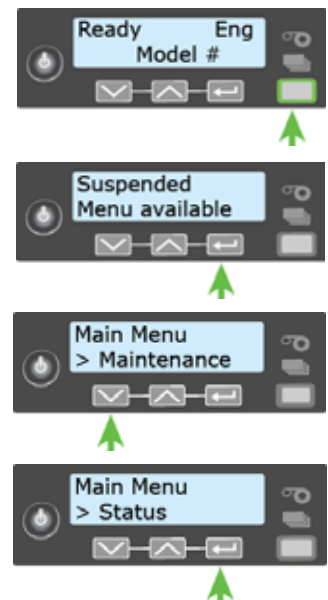

- e. Press the down arrow key twice to display **Network IPv4** on line 2.
  - f. Press ENTER to display the **Network IPv4** menu.
3. Press the down arrow key until **IP Address** displays on line 2.
  4. Press ENTER to display the IP address. Record the IP address.
  5. Press ENTER to return to the Network IPv4 menu. **Subnet Mask** displays on line 2.
  6. Press ENTER to display the subnet mask. Record it, if necessary.
  7. Press ENTER to return to the Network IPv4 menu. **Gateway Address** displays on line 2.
  8. Press ENTER to display the gateway address. Record it, if necessary.
  9. Press ENTER to return to the Network IPv4 menu.
  10. Press the down arrow key to scroll to **Exit** on line 2.
  11. Press ENTER. Then, press the USER button to return the printer to **Ready**. The USER button glows green.



## Retrieve an IPv6 Address

A printer on an IPv6 network can be configured to use one or more of the following methods, depending on how the network is set up:

- **Link Local IPv6 address:** The printer and PC clients are restricted to the same subnet. Link local is enabled automatically when IPv6 is enabled and offers the best security for your network.
- **DHCPv6:** A DHCPv6 server is externally configured to give out an IPv6 address.
- **Stateless Address AutoConfiguration (SLAAC):** One or more routers with IPv6 enabled on the subnet give out a subnet prefix that allows access to IP addresses.
- **Manual IPv6 Address:** The printer has a designated IPv6 address on a specified subnet. The address does not change without manual intervention. This is similar to an IPv4 static IP address.

The method used is enabled or disabled using the LCD Configuration menu. Refer to the printer's *Installation and Administrator's Guide* for more information about enabling IPv6.

To display an IPv6 address using the Status menu, do the following.

Begin with the printer power connected, and the printer connected to the network.

1. Press the POWER button (if needed) to power on the printer.
2. Access the **Status** menu in the LCD menu:
  - a. Press the USER button to suspend the printer.

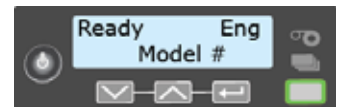

- b. Press ENTER to enter the menu system.



- c. Press the down arrow to display **Status** on line 2.



- d. Press ENTER to enter the **Status** menu.

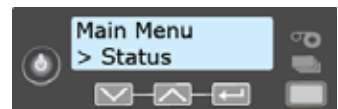

- e. Press the down arrow key until **Network IPv6** displays on line 2.

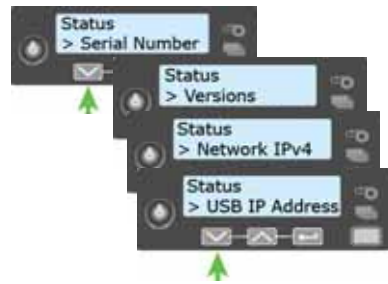

- f. Press ENTER to display the **Network IPv6** menu.



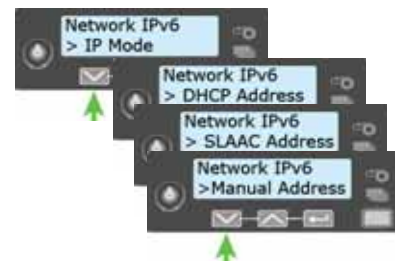

- 3. Press the down arrow key until the address method used by your network displays on line 2.

- DHCP
- SLAAC
- Manual
- Local

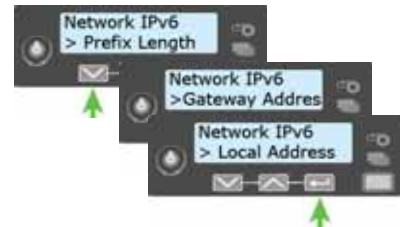

Press ENTER to display the IP address.



 The example shows the LCD display for an IPv6 Manual address. DHCP, SLAAC, and Local addresses behave the same, as does the gateway address for a manual address.

An IPv6 address is represented as eight groups of four hexadecimal digits separated by colons. The address requires 39 characters to display. Because the LCD is limited to 16 characters per line, the IPv6 address is spread across three screens of the LCD. You can press either the down arrow or the ENTER key to display the next section of the address. A digit at the end of line 1 indicates which section of the address is being displayed.

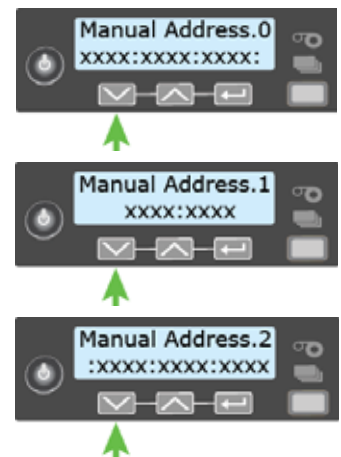



A stateless (SLAAC) configuration (if enabled) can have multiple values depending on the router setup. The LCD displays up to four SLAAC addresses. An additional digit in line 1 indicates which address is being displayed.

4. Record the address.
5. Press the down arrow key until **Exit** displays on line 2.
6. Press ENTER. Then, press the USER button to return the printer to **Ready**. The USER button glows green.

## Print a Test Card

The printer includes a test card that runs without using a driver or other source of card data. Use it to verify that the printer is working.

1. Begin with the printer **Ready**. The User button shows steady green.
2. Press the USER button to display **Suspended** on line 1 of the LCD panel.
3. Press ENTER to enter the menu system.
4. Press ENTER to enter the Maintenance menu.
5. Press the down arrow until **Test Card** displays on line 2.
6. With **Test Card** displayed on line 2, press ENTER to display **Start** on line 2.
7. Press ENTER to print the test card.  
After the card prints, the printer returns to **Ready**.

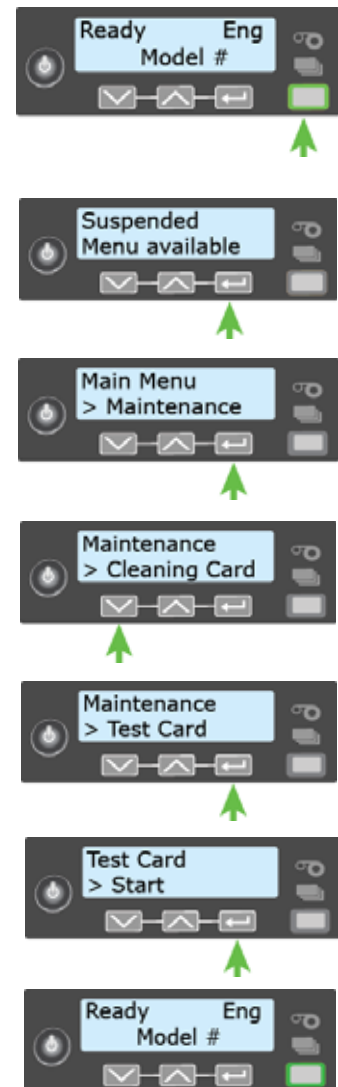

# Load and Replace Supplies

To prepare the printer to print cards, load blank card stock into the input hopper, and load print ribbon and a cleaning sleeve onto the print cartridge.

 If your system includes the optional laminator, also load overlay material into the L1 and L2 (if equipped) laminators. Refer to [“Load Laminator Overlay Material”](#) on [page A-8](#), for information about loading the laminator cartridges.

## Load Cards

If you plan to insert cards into the printer manually, skip this step and keep a supply of blank cards near the printer.

- Cards can stick together. Slide or fan the cards to separate the edges before placing them in the input hopper. Handle cards by their edges only, or wear gloves.
- Insert ISO magnetic stripe cards with the stripe (back side) facing down and to the right.
- Insert smart cards with the smart card chip facing up and toward the back of the hopper.

 A diagram inside the input hopper shows the correct orientation for each type of card.

## Single Hopper

1. Unlock the printer, if necessary, and open the input hopper.
2. Load the cards into the input hopper.
3. Close the input hopper and lock the printer, if necessary.

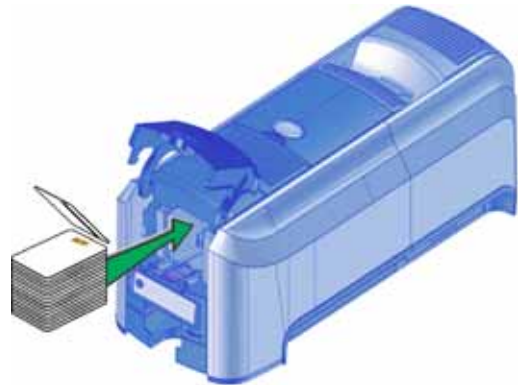

## Optional Multi-Hopper

1. Unlock the printer and open the multi-hopper cover.
2. Load the cards into the hoppers.  
The input hoppers are labeled H1 through H6. You can load up to 100 cards into each hopper.
3. Close the multi-hopper and lock the printer when you finish loading cards.

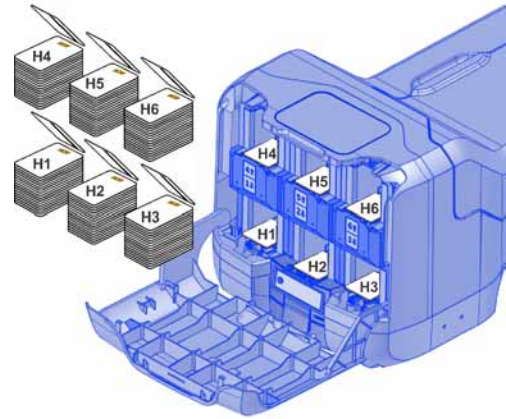

## Use the Exception Slot

The exception slot allows you to insert a single card, such as a different card type than those loaded in the input hopper. The input hopper does not have to be opened to insert a card through the exception slot.

Do the following to insert a single card into the printer using the exception slot.

1. Slide the card into the exception slot.
2. Push the card all the way into the input hopper. The card slides under any cards already in the input hopper so that it can be picked.



In a printer with the optional multi-hopper, the card slides under any cards in hopper 2.

# Load the Print Ribbon

Load the print ribbon when you install the printer and when the ribbon runs out.

1. Unlock the printer, if necessary, and open the printer supplies access door on the optional multi-hopper.
2. Open the printer cover.

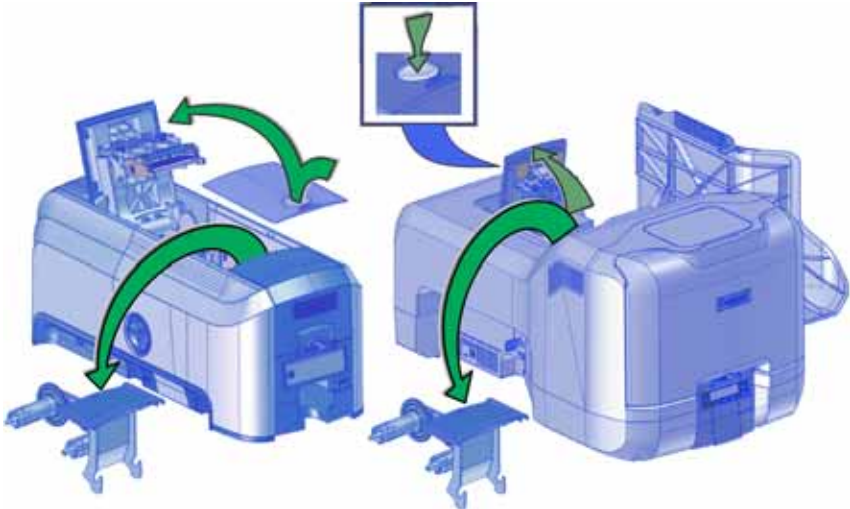

3. Remove the print ribbon cartridge.
4. Load a full roll of print ribbon (the blue spool) onto the spindle closest to the cartridge handle until it clicks into place.
5. Place the silver take-up spool on the spindle with the black gear until it clicks into place.
6. Wind the take-up spool counterclockwise one full turn.

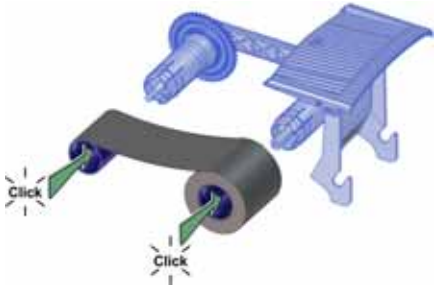



## Load the Cleaning Sleeve

Load a new cleaning sleeve when you load a new roll of print ribbon, when you notice debris on the printed cards, or when the cleaning sleeve is no longer sticky.

1. Remove the cleaning roller spindle with the used cleaning sleeve from the ribbon cartridge.
2. Remove the used cleaning sleeve from the spindle and discard it.
3. Slide the spindle into a new cleaning sleeve (a).
4. Place the spindle with the cleaning sleeve onto the ribbon cartridge (b).
5. Remove the protective wrapper from the cleaning sleeve (c).

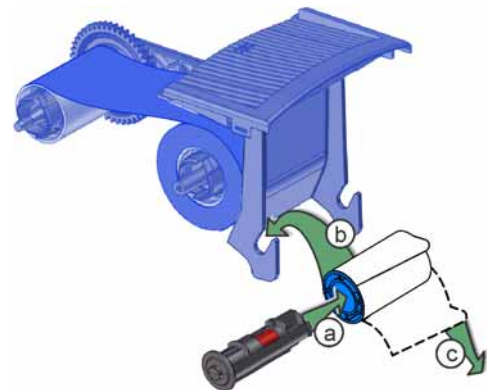

## Install the Ribbon Cartridge

Install the assembled print ribbon cartridge into the printer.

1. Open the printer cover.
2. Hold the print ribbon cartridge by the handle and lower it into the printer with the handle toward the front of the printer.

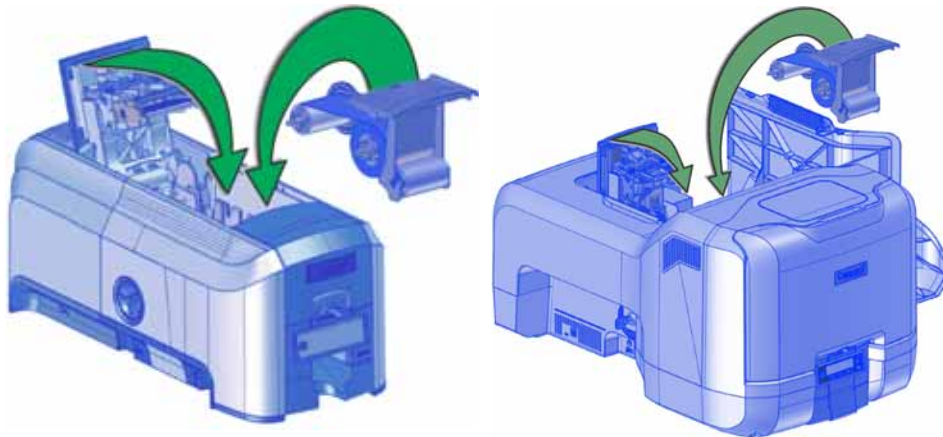

3. Make sure that the ribbon cartridge is positioned correctly in the guides.

4. Close the printer cover. Press down on the ridges on the front of the cover to make sure that it latches completely on both sides.
5. Close the supplies access door on the optional multi-hopper. Lock the printer, if necessary.

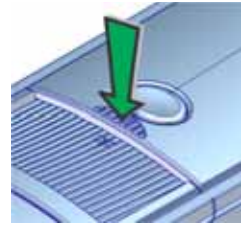



# Chapter 4: Printing Cards

# 4

---

## Before Starting to Print

This section explains how to print a card. Make sure that:

- Cards are loaded in the printer or available to insert.
- Ribbon is loaded in the printer. For the steps to follow, refer to [“Load the Print Ribbon”](#) on [page 25](#). If your system includes the optional laminator, refer to [Appendix A: “CLM Laminator”](#) for information about preparing the laminator.
- The card design is set up. If you need to set up or modify the design, refer to “Elements of Card Design” in the printer’s *Installation and Administrator’s Guide*, and the documentation for your card personalization software.

### HINTS & TIPS

- Make sure that magnetic stripe cards and smart cards are loaded correctly. A diagram inside the input hopper of the printer shows the correct card orientation.
- Do not touch the card surface to be printed. Handle cards by their edges, or wear gloves.

You also can:

- Print a test card directly from the printer. Refer to [“Print a Test Card”](#) on [page 22](#).
- Print a driver sample card. Refer to [“Print a Driver Sample Card”](#) in the printer’s *Driver Guide*.

# Print Cards

Make sure that cards are loaded in the printer or available to insert when prompted. For the steps to follow, refer to [“Load Cards”](#) on [page 23](#).

## Print from ID Software

1. Select the template or design for the card.
2. Select the printer, if you use more than one printer.
3. Enter the data for the card. Follow the instructions for your software.
4. Capture the photo for the card, if necessary.
5. Click the **Print** button to send the card to the printer.
6. At the printer, insert a card into the printer, if necessary.

## Print from Other Software

The following example illustrates how you can use Microsoft Word to design and print a card. Refer to your printer's *Driver Guide* for complete information about how to set up the XPS Card Printer Driver to print a card from the application.

1. Open Word and select **File > Print**.
2. Select the card printer as the current printer.
3. On the setup page, select **ISO ID-1** as the page size, or set the page size to 2.13 x 3.38 in.
4. Set the margins to 0 (zero).
5. Select an orientation—portrait or landscape.

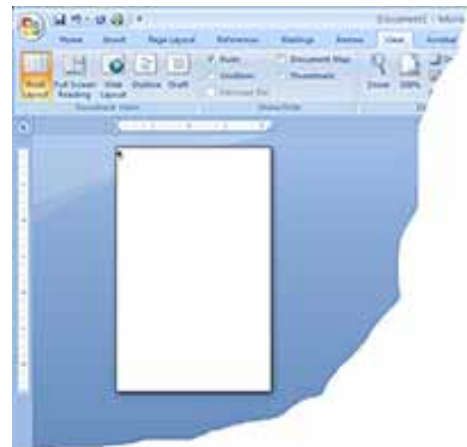

6. Create the card design:
  - a. Add graphics, such as a company logo or background.
  - b. Add a photo.
  - c. Add text information, such as name, address, or employee number.

For information about additional card features, refer to “Elements of Card Design” in the printer’s *Installation and Administrator’s Guide*.

7. Click **Print** to send the card to the printer.
8. At the printer, insert a card into the printer, if necessary.





# Chapter 5: System Maintenance

# 5

---

## Maintain the Printer

The printer performs best when it is cleaned on a regular basis. Follow the cleaning guidelines for your site to keep the printer in good working condition.

Clean the printer when:

- There is debris on completed cards.
- A new roll of print ribbon is installed.

You can perform the following cleaning tasks:

- [Clean the Printhead on page 34](#)
- [Run a Cleaning Card on page 36](#)
- [Clean the Laminator on page A-12](#)



# Clean the Printhead

Clean the printhead when:

- The printhead is replaced.
- There are unprinted lines on the finished card. This usually indicates dirt or contaminants on the printhead.
- The printhead is touched accidentally. Oils from hands can affect print quality and damage the printhead.

Do the following to clean the printhead:

1. Power off the printer.
2. Unlock the printer, if necessary, and open the printer supplies access door on the optional multi-hopper.
3. Open the printer cover and remove the print ribbon cartridge.

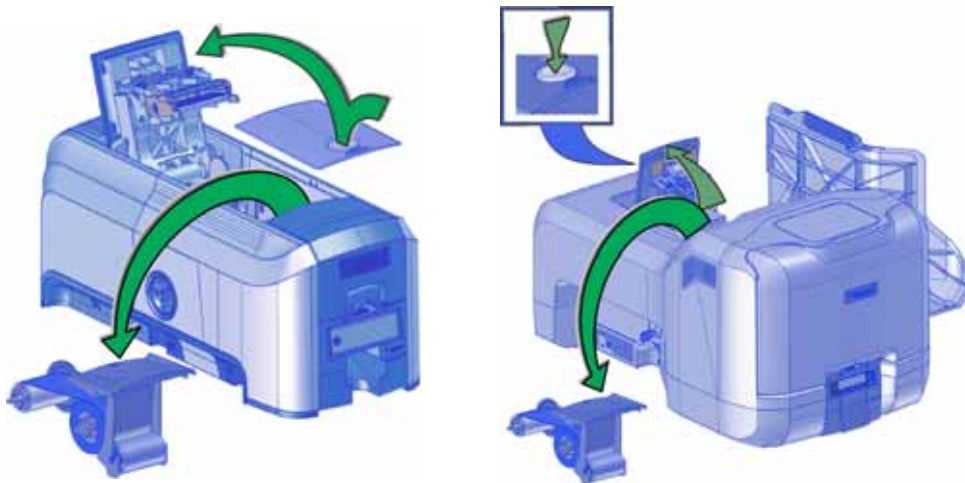

4. Open and remove a cleaning swab from its package.
5. Use gentle pressure, move the cleaning swab back and forth along the full length of the printhead edge until it is completely clean.

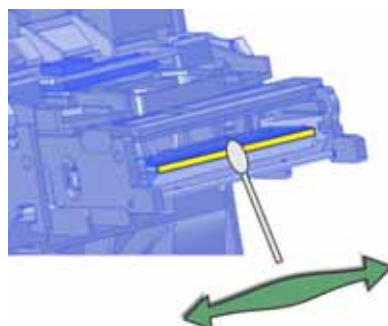

6. Replace the print ribbon cartridge. Avoid bumping the printhead when you install the print ribbon cartridge.

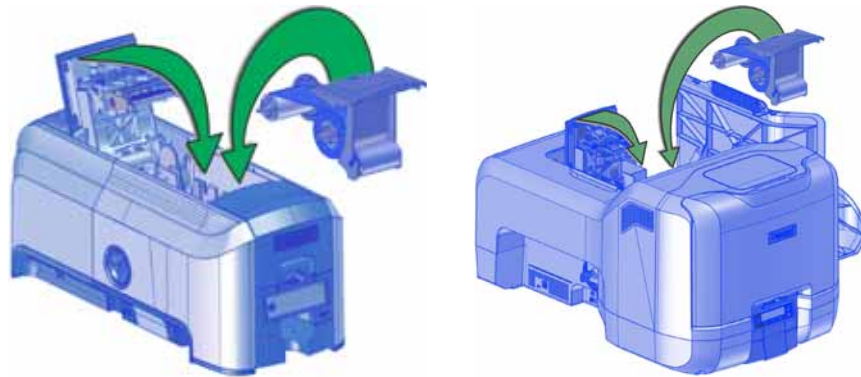

7. Close the printer cover. Press down on the ridges on the front of the cover to make sure that it latches completely on both sides. Close the supplies access door on the optional multi-hopper and lock the printer, if necessary.
8. Power on the printer.
9. Print a sample card to verify the quality of printing. Refer to [“Print a Test Card”](#) on [page 22](#) for more information.

#### HINTS & TIPS

- Avoid touching the printhead edge with your fingers. Contamination due to skin oils eventually can damage the printhead.
- Avoid touching the printing edge of the printhead cartridge with any sharp objects that can permanently damage the printhead.
- Use only the cleaning swab to clean the printhead. Other materials can stick to the printhead and cause damage.
- Use a cleaning swab one time only. Discard it after you clean the printhead.

# Run a Cleaning Card

Run a cleaning card to clean debris from the inside of the printer and from the input hopper rollers. The cleaning card can remove most contaminants from the printer. Run a cleaning card after every 500 cards processed by the printer, or more often depending on your environment, or if print quality diminishes.

## Single Hopper

1. Prepare the printer for cleaning.
  - a. Power on the printer.
  - b. Unlock the printer, if necessary.
  - c. Open the printer cover and remove the print ribbon cartridge.
  - d. Close the cover.
  - e. Open the input hopper and remove any unprinted cards.
  - f. Open the cleaning card package and remove the cleaning card.
  - g. Load the cleaning card in the input hopper. (Plan to clean the printer immediately. The cleaning card dries out if it is out of its package for more than a few minutes.)
  - h. Close the input hopper and lock the printer, if necessary.

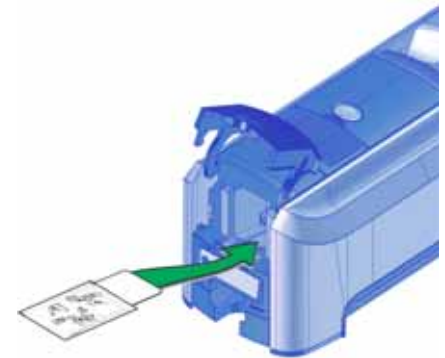
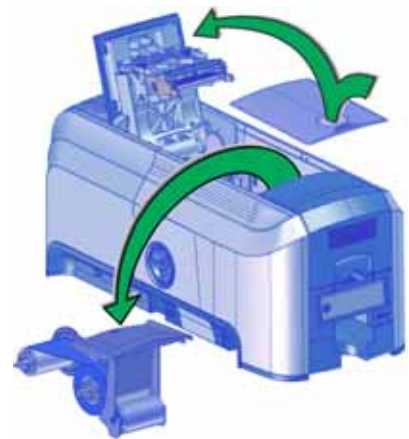

2. Use the LCD menu system to start the cleaning cycle.

a. Begin when the printer displays **Ready** and the USER button shows steady green. Press the USER button.

**Suspended** displays on line 1 of the LCD panel.

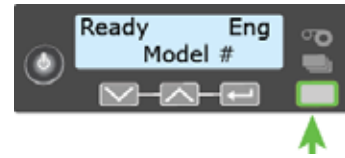

b. Press ENTER to enter the menu system.



c. **Maintenance** displays on line 2 of the LCD panel. Press ENTER to enter the **Maintenance** menu.



d. **Cleaning Card** displays on line 2 of the LCD panel. Press ENTER to enter the **Cleaning Card** menu.

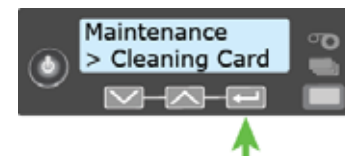

e. **Start** displays on line 2 of the LCD panel. Press ENTER to start the cleaning process.

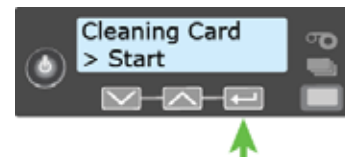

f. **Insert cleaning card** displays on the LCD panel. Press the USER button to start the cleaning cycle.

The printer moves the card through the printer several times and ejects it into the output hopper.

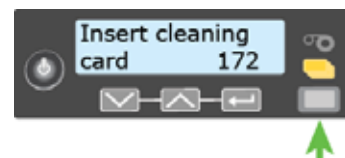

If you are cleaning a system with a laminator, the cleaning card moves into the laminator after cleaning the printer and cleans the laminator rollers and card entry area. The cleaning card is ejected into the laminator output hopper.

3. Remove the used cleaning card. Wait a few minutes for the rollers to dry.

4. Prepare the printer for use.
  - a. Unlock the printer, if necessary.
  - b. Replace the cards in the input hopper.
  - c. Install a new cleaning sleeve on the ribbon cartridge and remove the protective cover. Refer to [“Load the Cleaning Sleeve”](#) on [page 26](#) for the steps to follow.
  - d. Replace the ribbon cartridge and close the printer cover. Press down on the ridges on the front of the cover to latch it completely.

Press the USER button to return the printer to **Ready**. The printer is available to print cards again.

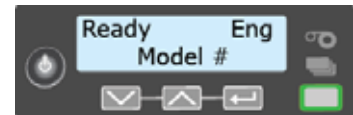

- e. Discard the used cleaning card and cleaning sleeve.

#### HINTS & TIPS

- Use the cleaning card and cleaning sleeve one time only.
- Change the cleaning sleeve each time you clean the printer or change the print ribbon.



If the card light is blinking amber and there are cards in the input hopper, the printer's configured cleaning count has been reached and it is time to clean the printer. The cleaning count is set in Printer Manager. Refer to the printer's *Installation and Administrator's Guide* for complete information about using Printer Manager.

## Optional Multi-Hopper

Cleaning a printer equipped with the optional multi-hopper involves two steps: cleaning the printer and cleaning the hopper rollers. To start the cleaning process, refer to “[Prepare the Printer for Cleaning](#)”.

### Prepare the Printer for Cleaning

1. Power on the printer.
2. Unlock the printer and open the printer supplies access door.
3. Open the printer cover and remove the print ribbon cartridge.
4. Remove the used cleaning sleeve from the ribbon cartridge. (The ribbon must remain installed on the ribbon cartridge.)
5. Replace the ribbon cartridge in the printer and close the cover.
6. Open the multi-hopper door and remove any unprinted cards.
7. Open the cleaning card package, remove the cards, and insert the cleaning cards into the hoppers. (Plan to run the cleaning cards immediately. The cleaning cards dry out if they are out of the package for more than a few minutes.)
8. Close the multi-hopper door and lock the printer. The front panel displays **Ready** and the USER light shows steady green.

Continue with “[Clean the Printer](#)” on [page 40](#).

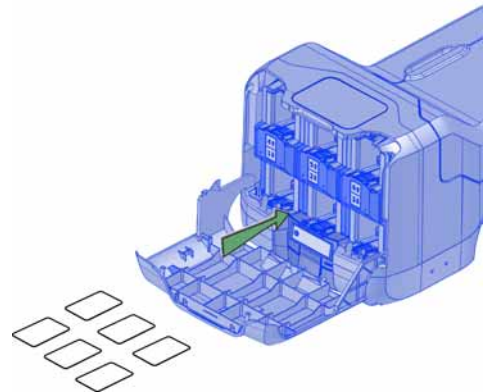
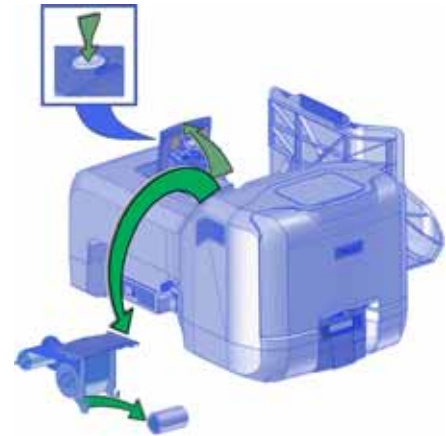

## Clean the Printer

1. Make sure that you have prepared the printer for cleaning. Refer to [“Prepare the Printer for Cleaning”](#) on page 39.

2. Press the USER button.

**Suspended** displays on line 1 of the LCD panel.

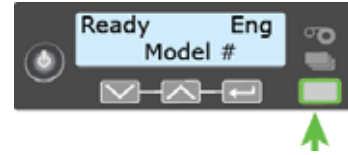

3. Press ENTER.



4. **Maintenance** displays on line 2 of the LCD panel. Press ENTER to enter the **Maintenance** menu.



5. **Cleaning Card** displays on line 2 of the LCD panel. Press ENTER to enter the **Cleaning Card** menu.



6. **Printer** displays on line 2 of the LCD panel. Press ENTER.



7. **Start** displays on line 2 of the LCD panel. Press ENTER to start the cleaning process.

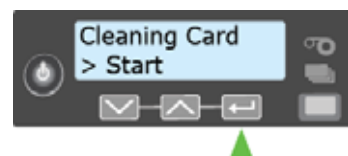

8. **Insert cleaning card** displays on the LCD panel. Press the USER button to start the cleaning cycle.

The printer picks the cleaning card from hopper 2 (H2) and moves it through the printer several times. The used cleaning card is placed in the reject tray.

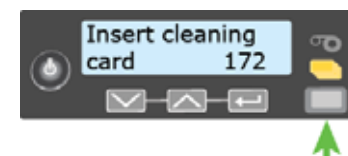

The printer returns to **Ready** when the cleaning cycle completes.

Continue with [“Clean the Multi-Hopper Rollers”](#) on page 41.

## Clean the Multi-Hopper Rollers

1. Access the LCD menu system and enter the **Cleaning Card** menu, as described in [“Clean the Printer”](#) on page 40.
2. Select the hoppers for cleaning.
  - a. Press the down arrow key until **Hopper** displays on line 2 of the LCD panel.
  - b. Press ENTER to enter the Hopper menu.
  - c. Press the down arrow key and choose **All** to clean hoppers H1 through H6. (Or, continue pressing down to select hoppers 1 through 6 to clean a hopper individually.)
3. Press ENTER to start the cleaning process.

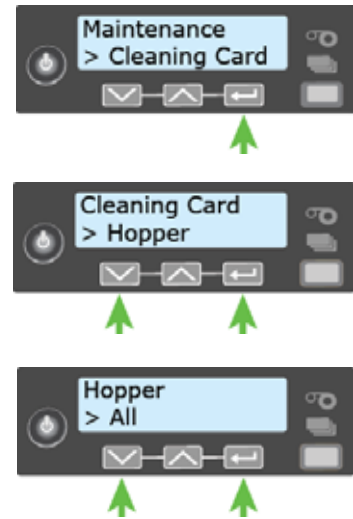

The printer moves the cleaning cards back and forth across the hopper rollers several times and then ejects the cleaning cards back into the hoppers.

The printer returns to **Ready** when the cleaning cycle completes.

To complete the cleaning process, continue with [“Prepare the Printer for Use”](#).

## Prepare the Printer for Use

1. Unlock the printer and open the multi-hopper door.
2. Remove the used cleaning cards from the hoppers.
3. Replace the unprinted cards in the input hoppers.
4. Open the printer supplies access door and the printer cover. Remove the print ribbon cartridge.
5. Install a new cleaning sleeve on the ribbon cartridge and remove the protective cover. Refer to [“Load the Cleaning Sleeve”](#) on page 26 for the steps to follow.
6. Replace the ribbon cartridge.
7. Close the printer cover. Press down on the ridges on the front of the cover to latch it completely.
8. Close the printer supplies access door.
9. Open the reject tray and remove the used cleaning card.

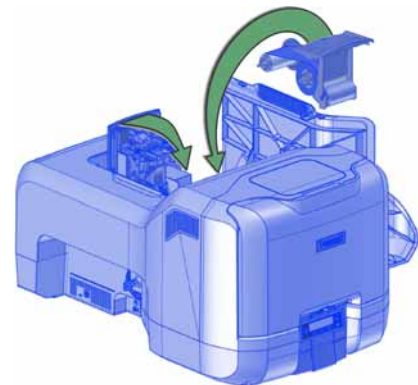



10. Lock the printer.

The printer returns to **Ready** and is available to print cards again.

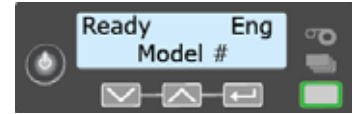

11. Discard the used cleaning cards and cleaning sleeve.

**HINTS & TIPS**

- Use the cleaning cards one time only.
- Change the cleaning sleeve each time you clean the printer or change the print ribbon.



# Chapter 6: Troubleshooting



---

This section helps you identify and fix basic issues that can occur during printing. Also refer to your printer's *Driver Guide* or OpenCard manual for additional troubleshooting information.

The section starts with an overview of card production and printer issues you may encounter:

- [Locate a Problem Within the Card Production System on page 44](#)
- [Locate a Problem with Basic Printer Functions on page 45](#)

This section also describes troubleshooting for the following:

- [Installation Problems on page 46](#)
- [Card Printer Driver Problems on page 48](#)
- [Card Appearance on page 51](#)
- [Magnetic Stripe Problems on page 57](#)
- [Laminator Problems on page 59](#)
- [Card Jams on page 64](#)
- [Repair a Broken Ribbon on page 65](#)
- [Messages and Conditions on page 65](#)

# Locate a Problem Within the Card Production System

For typical components of the system, refer to “[Card Printer System Overview](#)” on [page 12](#). If any one of the following components does not work properly, printing cards can be affected.

- The XPS Card Printer Driver

If you need to reinstall the Card Printer Driver to fix a problem, we recommend you download the latest version of the driver from <http://www.datacard.com>. Select **Support & Drivers > Drivers & Downloads** from the menu. Enter your printer model in the Enter Product Name or Number area, and click **Go**.

- Card production software

Card production software formats the types of data used to print cards. Make sure that the card production software features you use work with your printer.

If you do not use card production software, make sure that the software you use supports the requirements for creating cards. If you use magnetic stripe data, use an application that saves text as text and not as a graphic. (For example, Microsoft Paint only saves graphic data, while Adobe Photoshop saves both graphic and text data.) Fonts and escapes require that text is sent from the application as text.

- Printer plug-in

Card production software might require a printer plug-in, which makes the data in the card production software available in the form the Card Printer Driver can use.

- Other components of the system

An ID or badge system usually includes a camera to take photos, and may include other capture devices for biometric data. The proper use and maintenance of these components is important to the quality of cards you produce.

# Locate a Problem with Basic Printer Functions

If the system is not working as expected, follow these steps in the order listed to isolate the source of the problem before you contact your service provider.

1. Make sure that the power cord is plugged in and the printer is powered on.
2. Does the printer power on and display **Ready** on the front panel within 1 minute?
  - If the printer powers on correctly, continue to step 3.
  - If the printer powers on, but **Improper Shutdown** displays on the LCD panel, press the USER button for approximately 2 seconds. **Ready** should display.
  - If the printer powers on but does not display **Ready**, the printer is not working properly. Request service for the printer.
  - If the printer does not power on, make sure that the printer power supply is working properly.
    - ◆ If the power supply is working properly, request service for the printer from your system administrator.
    - ◆ If the power supply is not functioning, replace it and begin with step 1.
3. Print a test card from the printer front panel. Refer to “[Print a Test Card](#)” on [page 22](#) for more information.
  - If the test card prints, the printer is working correctly. Continue to step 4.
  - If the test card does not print, the printer is not working correctly. Request service for the printer.
4. Connect the printer data cable, if necessary. Make sure that you use the same type of cable (USB or network) used when the printer was installed.
5. If you use the XPS Card Printer Driver, print a driver sample card. For the steps to follow, refer to your printer’s *Driver Guide*.
  - If the sample card prints, the printer and driver are working correctly. Continue to step 6.
  - If the sample card does not print, the printer and driver have a communication problem. Determine the cause of the problem and try the sample card again.

If you are not using the Card Printer Driver, ask your service provider or software provider for assistance.

6. Print a card using your card production software.
  - If the card prints, your software is working successfully with the printer. Troubleshoot the card design, if necessary.
  - If the card does not print, check the following:
    - ◆ In the application, is the correct printer selected in the Print Setup or Print dialog?
    - ◆ If the printer produced a blank card, review the page size or other settings.

If the card causes an error, the card might have a type of data the printer does not support.

## Installation Problems

This section describes issues that prevent a successful installation and provides recommended solutions to those issues. Choose from the following topics:

- [USB Installation Troubleshooting](#)
- [Network Installation Troubleshooting on page 48](#)

## USB Installation Troubleshooting

Problem	Solution
The cable is loose.	Reconnect the USB cable to the ports on the PC and the printer. Power the printer off, and then back on. If the PC and printer still do not communicate, restart the PC.
The data cable is damaged or frayed.	Power off the printer. Replace the cable if you have a spare. Contact your service provider to order a new data cable.
The system has a temporary communication problem.	Check for the following: <ul data-bbox="638 674 1369 852" style="list-style-type: none"><li data-bbox="638 674 1369 772">• USB extension cables can cause communication problems. The recommended USB cable is 6-ft. (2 meters) long. Make sure that the cable is rated for USB 2.0 data transmission.</li><li data-bbox="638 789 1369 852">• If you are using a USB hub, a self-powered hub is recommended.</li></ul>
The PC USB port does not communicate with the printer USB port.	Power management on the PC has shut down USB communication. Check the following: <ul data-bbox="638 968 1369 1251" style="list-style-type: none"><li data-bbox="638 968 1369 1066">• Open Device Manager and the list of USB devices. Disable shutdown for each hub in the list. Restart the PC to make the changes take effect, if necessary.</li><li data-bbox="638 1083 1369 1182">• Hibernation on a laptop requires several moments to enable USB communication. Unplug the USB printer port and then connect it again.</li><li data-bbox="638 1199 1369 1251">• Replace the PC port or the PC. Contact your PC or port vendor if you need assistance.</li></ul>

## Network Installation Troubleshooting

Problem	Solution
The network cable is loose.	Reconnect the data cable to the network port and the printer. Restart the printer.
The Status page of Printer Properties shows the printer is not available, but the printer displays <b>Ready</b> on the LCD panel.	Follow your network troubleshooting procedures to isolate and test each component of the computer-to-printer communication link. Suggestions: <ul style="list-style-type: none"><li>• Verify the computer-to-network connection by accessing a network resource, such as a network drive.</li><li>• The network administrator can test communication between a server and the printer.</li><li>• Make sure that the user is logged on to the network.</li></ul>
The printer is not configured with the correct network address	Make sure that the server name or IP address is entered in the Port Settings or Configure Port dialog box on the computer. For more information about retrieving the printer's IP address, refer to <a href="#">"Retrieve the Printer's Network IP Address"</a> on <a href="#">page 18</a> . Make sure that <b>Ready</b> displays on the printer's LCD panel.

## Card Printer Driver Problems

The Card Printer Driver and printer can have the following communication problems:

- [The Card Printer Driver does not detect the network-connected printer on page 49.](#)
- [The Card Printer Driver does not detect the USB-connected printer on page 49.](#)
- [Driver status or Windows print queue does not provide expected data on page 50.](#)
- [Printer Messages do not display on the PC on page 51](#)

## The Card Printer Driver does not detect the network-connected printer

Problem	Solution
The <b>Printer Properties &gt; Status</b> tab shows the printer is not available.	Make sure that you use the same type of data cable—USB or network—that was used when the printer was installed. You cannot switch the type of data cable after installation. Make sure that the current printer IP address is the same as the IP address on the <b>Printer Properties &gt; Ports</b> tab. For more information about retrieving the printer's IP address, refer to <a href="#">"Retrieve the Printer's Network IP Address"</a> on page 18.
Message 500 displays after you send a card to print.	If this happens often, consider switching from DHCP network addressing to static IP addressing. For more information about setting the Card Printer Driver network communication value, refer to the "Printer Manager" section of the card printer's <i>Installation and Administrator's Guide</i> .
The network is not operating properly.	Test the network using another device and fix or report network problems. To test the network, print to a different (paper) printer or verify the availability of network drives.
The printer is not connected to the network, or the PC is not connected to the network.	Make sure that both ends of the data cable are connected. Replace defective cables if needed.

## The Card Printer Driver does not detect the USB-connected printer

Problem	Solution
The <b>Printer Properties &gt; Status</b> tab shows the printer is available, but Message 500 displays after you send a card to print.	Make sure that you use the same type of data cable—USB or network—that was used when the printer was installed. You cannot switch the type of data cable after installation. Make sure that both ends of the data cable are connected. Replace a defective USB cable if needed.



## Driver status or Windows print queue does not provide expected data

Problem	Solution
<p>The Card Printer Driver sample card or magnetic stripe test cards do not print.</p>	<p>Check the following:</p> <ul style="list-style-type: none"> <li>• <b>Enable bidirectional support</b> must be selected on the <b>Printer Properties &gt; Ports</b> tab to allow printing from the Card Printer Driver.</li> <li>• If <b>Print directly to printer</b> is selected in the <b>Printer Properties &gt; Advanced</b> tab, clear the selection to allow printing of the Card Printer Driver sample cards.</li> </ul>
<p>The Ribbon Low light on the printer and the Card Printer Driver status do not match.</p>	<p>The percentage of ribbon remaining that causes the printer Ribbon Low light can be set using the Printer Manager <b>FrontPanel</b> printer setting. The driver displays the actual percentage of ribbon remaining and cannot be changed. As a result, the indicators may not be in agreement.</p>
<p>A print job disappears from the print queue but does not print.</p>	<p>The printer USB cable was disconnected after the application sent the job. Reconnect the cable and try the job again.</p>
<p>The Card Printer Driver <b>Printer Status</b> page shows a USB-connected printer as <b>Ready</b>, but a card sent to the printer does not print.</p>	<p>The Windows print queue is offline. This can result if the printer is powered on before the computer. Do one of the following:</p> <ul style="list-style-type: none"> <li>• Unplug the USB cable, and plug it back in.</li> </ul> <p>or</p> <ul style="list-style-type: none"> <li>• Place the print queue online: <ul style="list-style-type: none"> <li>– Open the Devices and Printers control panel.</li> <li>– Right-click the printer icon and select <b>See what's printing</b> to display Windows Print Manager.</li> <li>– Clear the check mark from <b>Use Printer Offline</b> in the Printer drop-down list.</li> </ul> </li> </ul> <p>We recommend that you turn on the PC and wait until it has started. Then, power on the printer.</p>

## Printer Messages do not display on the PC

Problem	Solution
A USB-connected printer issues a message on the LCD but the message does not display on the PC.	<p>Windows has a 15-character limit for the computer name. If the computer name is longer than 15 characters, it treats the name as not valid and does not display the message. Do the following to change the computer name:</p> <ol style="list-style-type: none"><li>1. Press the <b>USER</b> button on the printer to clear the message on the LCD.</li><li>2. On the PC, open <b>Control Panel/System and Security/System</b>.</li><li>3. Locate the computer name and click <b>Change settings</b>.</li><li>4. On the Properties window, click <b>Change</b> next to the rename this computer... field</li><li>5. Enter the new computer name on the <b>Computer Name/Domain Changes</b> dialog box and click <b>OK</b>.</li></ol> <p><b>Note:</b> If your computer is part of a corporate domain, you may not be allowed to change the computer name. Contact your network administrator for more information.</p>

## Card Appearance

Card appearance problems can be caused by many different factors. Click the link below that best describes the card appearance issue on the printed card.

- [Something did not print on page 52](#)
- [Printing includes unexpected data on page 53](#)
- [The color printing has flaws on page 53](#)
- [The printing is too light on page 55](#)
- [The printing is too dark on page 55](#)
- [The monochrome printing has flaws on page 56](#)

## Something did not print

Problem	Probable Cause	Solution
Nothing is printed on the card.	The Disable Printing option in the Card Printer Driver is set to All, Front, or Back.	Open the <b>Preferences &gt; Layout &gt; Advanced</b> tab and change <b>Disable Printing</b> to <b>Off</b> .
	The print ribbon is loaded incorrectly.	Remove the print ribbon and install it correctly.
	The page size was not set to ISO ID-1.	Use your card production application to access the printer's print setup and select <b>ISO ID-1</b> for the page size. The correct page size is available after you select the printer.
Printing is not visible.	The entire card was printed using the UV (F) panel.	Print only small areas of text and images using the UV panel.
Color printing on top of a black background does not print on the card.	The black panel of the ribbon is printing over the color panels.	The printer uses the print ribbon panels in sequence; the Y panel prints first, then M, and so on. The black panel of the print ribbon is used last and prints over the color panels. For best results, change the 100% black background to a color near black, so that it prints using the YMC (color) panels of the print ribbon. Refer to "Elements of Card Design" in the printer's <i>Installation and Administrator's Guide</i> for more information about color printing.

## Printing includes unexpected data

Problem	Probable Cause	Solution
Text that was intended for the magnetic stripe printed on the card instead.	The magnetic stripe font was not applied to the text.	Refer to "Magnetic Stripe Fonts" in the printer's <i>Driver Guide</i> .
	The escape was typed incorrectly.	Refer to "Magnetic Stripe Escapes" in the printer's <i>Driver Guide</i> .
	The text to encode was longer than one line.	Reduce the font size to keep all text on one line.
Several blank cards are ejected before the full card prints.	The application uses the page size that is in effect when a card design document is created. Setting the page size after creating the document can cause errors.	Use the page setup feature of the application to set the page size before creating the document. Consider creating a template for cards that opens at the correct page size.

## The color printing has flaws

Problem	Probable Cause	Solution
One or more lines appear on the card.	The printhead is dirty or damaged.	Clean the printhead. Refer to " <a href="#">Clean the Printhead</a> " on <a href="#">page 34</a> .
The print quality changes from the previous card.	The ribbon type was changed while card jobs were in the printer queue.	The type of ribbon installed in the printer determines the color profile used when the card is sent to print. If the ribbon type changes while jobs are queued, the card may not print correctly. Allow all queued jobs to complete before changing the type of ribbon in the printer. Changing to a ribbon of the same type does not affect printing.
One color panel is not aligned correctly with other color panels.	The cards are slipping in the track.	Run a cleaning card. Refer to " <a href="#">Run a Cleaning Card</a> " on <a href="#">page 36</a> .
	The cards are not the correct size for the printer.	Use cards that meet the size requirement for the printer. Refer to "Cards" in the printer's <i>Installation and Administrator's Guide</i> for specifications. If you must use the cards you have, ask your system administrator for help.

Problem	Probable Cause	Solution
Printing is blurred.	The cards have a matte, not glossy, finish.	Use cards that meet the requirements for the printer. Refer to "Cards" in the printer's <i>Installation and Administrator's Guide</i> for specifications.
	The rollers are dirty.	Run a cleaning card. Refer to "Run a Cleaning Card" on page 36.
	The printhead is dirty.	Clean the printhead. Refer to "Clean the Printhead" on page 34.
The printed card has small unprinted areas.	Unprinted cards have scratches.	Handle cards carefully. Refer to "Card Quality Guidelines" in the printer's <i>Installation and Administrator's Guide</i> .
	Cards have embedded particles, an uneven surface, or the card edge has burrs.	Use cards that meet the requirements for the printer. Refer to "Cards" in the printer's <i>Installation and Administrator's Guide</i> .
	The rollers are dirty or the card packaging contains debris.	Run a cleaning card. Refer to "Run a Cleaning Card" on page 36.
Part of the printed image is discolored.	Cards have fingerprints or other dirt on them.	Handle cards carefully. Refer to "Card Quality Guidelines" in the printer's <i>Installation and Administrator's Guide</i> .
	A signature panel is located on the other side of the card.	Design the card to avoid printing photos over signature panel residue.
	The rollers are dirty or the card packaging contains debris.	Run a cleaning card. Refer to "Run a Cleaning Card" on page 36. Use cards that meet the requirements for the printer. Refer to "Cards" in the printer's <i>Installation and Administrator's Guide</i> .

## The printing is too light

Problem	Probable Cause	Solution
Photos look faded.	The image capture system needs adjustment.	Color settings might not be optimal. Adjust color settings. Refer to the documentation for the image capture system, "Color Printing" in the printer's <i>Installation and Administrator's Guide</i> , and "Color Adjustment Tab" in the printer's <i>Driver Guide</i> .
The printing is very light.	The ribbon is loaded incorrectly.	Load the print ribbon correctly. Refer to "Load the Print Ribbon" on page 25.
	The card was previously printed and has topcoat on it.	Print only new cards. Refer to "Cards" in the printer's <i>Installation and Administrator's Guide</i> .
	The printhead is not installed correctly.	Contact your service provider for instructions to install the printhead correctly.
	The printhead power is too low.	Log on to the Printer Manager as a WebAdmin. Open the <b>Printer Settings &gt; Print</b> menu. Increase the YMCPower setting, and click <b>Set Current</b> to save your changes.

## The printing is too dark

Problem	Probable Cause	Solution
The card shows wrinkles in darkly colored areas.	The card includes very dark areas.	Change the design to use smaller areas of dark color.
	The printhead is not aligned correctly.	Contact your service provider.
All color printing is darker than intended.	Color adjustment is too dark. A change in the card stock you use can alter the appearance of printed cards.	Change the color adjustment settings. Refer to "Color Printing" in the printer's <i>Installation and Administrator's Guide</i> , and "Color Adjustment Tab" in the printer's <i>Driver Guide</i> .

# The monochrome printing has flaws

Problem	Probable Cause	Solution
Text has broken (partly printed) characters.	The monochrome (K) power setting is balanced to print both fine text and bar codes.	If the card does not include a bar code, increase the monochrome intensity. If the card includes fine text and bar codes, change the text to improve printing. Refer to "Monochrome Printing" in the printer's <i>Installation and Administrator's Guide</i> .
	The text is formatted to print with color, and the card is being printed with monochrome ribbon.	Contact your service provider. Format text to print black so that the text is not dithered.
Printing is uneven or is missing in some areas.	The monochrome (K) power setting is too low. The cards require a different setting.	Increase the monochrome intensity. Find a balance between printing all card data and causing wrinkles.
A black-and-white image prints using the color panels.	The Windows Picture Print Wizard or Picture and Fax Viewer is printing the file. Many applications use the Windows tool to preview and print graphics. The tool does not render to true black and white.	Use another application, such as ID software or Microsoft Word, to create the card.

# Magnetic Stripe Problems

To begin troubleshooting a magnetic stripe problem, first print a magnetic stripe test card from Printer Manager or the Card Printer Driver. For the steps to follow, refer to the “Printer Manager” section of the printer’s *Installation and Administrator’s Guide* or “Print a Driver Sample Card” in the card printer’s *Driver Guide*.

The printer uses the coercivity set using the LCD panel or in Printer Manager, and the data format set using Printer Manager.

Problem	Solution
Cards are not loaded correctly.	Load ISO cards with the magnetic stripe (back side) facing down and to the right. Refer to “Load Cards” on <a href="#">page 23</a> .
Cards do not have a magnetic stripe.	Load magnetic stripe cards in the input hopper. If the cards have a magnetic stripe, check the quality of the cards. Change card stock, if needed.
The card has dirt or damage on the magnetic stripe.	Encode and send a new card to print. If an error message displays indicating a magnetic stripe problem, run a cleaning card to clean the magnetic stripe head. Refer to “Run a Cleaning Card” on <a href="#">page 36</a> .
The magnetic stripe on the card is low-coercivity material and the High Coercivity setting is selected.	To use the cards you have, select low-coercivity encoding. Refer to the Printer Manager “Printer Setting Menu” in the <i>Installation and Administrator’s Guide</i> for more information. To encode with high coercivity, obtain cards manufactured for high-coercivity encoding. Refer to “Print a Test Card” on <a href="#">page 22</a> .
The magnetic stripe on the card is high-coercivity material and the Low Coercivity setting is selected.	To use the cards you have, select high-coercivity encoding. Refer to the Printer Manager “Printer Setting Menu” in the <i>Installation and Administrator’s Guide</i> for more information. To encode with low coercivity, obtain cards manufactured for low-coercivity encoding.
The data for this job includes characters not allowed by the magnetic stripe format selected for the track.	Cancel the current print job. Make sure that you know which characters are allowed on the track. Change the data to be encoded, and resend the print job. Refer to “Magnetic Stripe Design” in the printer’s <i>Installation and Administrator’s Guide</i> for more information.



Problem	Solution
<p>The magnetic stripe data was sent in an encoding format not supported by the track.</p>	<p>Review the encoding format setting for the tracks in Printer Manager. Refer to the Printer Manager “Printer Setting Menu” in the <i>Installation and Administrator’s Guide</i>. Make sure that the application is using the selected encoding format for the track.</p> <p>If the application and track are set to the same format, and the error message displays repeatedly, contact the application provider for assistance.</p>
<p>The application sent track data for a track not supported by the magnetic stripe module.</p>	<p>Verify the type of magnetic stripe option in the printer.</p> <p>If the printer label indicates a 3-track ISO module, you can send data for tracks 1, 2, and 3.</p> <p>If the printer label indicates a single-track JIS module, you can send data for track 1.</p> <p>The magnetic stripe option and cards must be capable of accepting and encoding each track of data sent by the card production software.</p>

# Laminator Problems

This section describes problems that might occur when you use a laminator to apply a patch or topcoat overlay to the card.

## Patch Appearance Problems

Problem	Probable Cause	Solution
Smart cards don't work after the overlay is applied.	The Debow card option is selected.	Make sure that the Debow card option in the Card Printer Driver is not selected. Refer to the printer's <i>Driver Guide</i> for information about specifying the debow option.
Cards are bowed too much.	The Debow card option is not selected.	Select the Debow card option in the Card Printer Driver. Refer to the printer's <i>Driver Guide</i> .
	Debow time is not set correctly.	Change the card debow time. Refer to the Printer Manager "Laminator" section of the printer's <i>Installation and Administrator's Guide</i> .
	The temperature is too high for the card stock used.	Lower the laminator temperature for the overlay material. Refer to the Printer Manager "Laminate Type" section of the printer's <i>Installation and Administrator's Guide</i> .
	The card stock doesn't work with the overlay.	Switch to a different card stock.
The patch comes off when the card is flexed.	The temperature is too low for the overlay material.	Increase the laminator temperature for the overlay material. Refer to the Printer Manager "Laminate Type" section of the printer's <i>Installation and Administrator's Guide</i> .
	A patch is stuck to the heated roller.	Clean the laminator. Refer to " <a href="#">Clean the Laminator</a> " on <a href="#">page A-12</a> . If the problem continues to occur, contact your service provider.

Problem	Probable Cause	Solution
There are scratches or particles under the patch.	The inside of the printer is dirty.	Clean the printer. Refer to <a href="#">“Run a Cleaning Card”</a> on page 36.
	The supplies have debris on them.	Store and handle supplies carefully. Keep supplies in the original packaging until you are ready to use them.
There are repeating marks on the patch.	The heated roller is dirty.	Clean the laminator. Refer to <a href="#">“Clean the Laminator”</a> on page A-12. If the problem continues to occur, contact your service provider.
The patch doesn’t adhere to the trailing edge of the card.	The overlay is wound incorrectly on the take-up spool.	Process another card to allow the overlay material to reset itself. If it doesn’t, remove the cartridge and turn the take-up spool clockwise several turns.
The patch is not centered between the long edges of the card.	The overlay is not loaded correctly in the cartridge.	Load the overlay material correctly. Refer to <a href="#">“Load Laminator Overlay Material”</a> on page A-8.
	The laminator cartridge is not fully seated in the laminator.	Make sure that the cartridge is seated in the laminator properly.
	The overlay material is wound unevenly on the supply roll.	Process several cards to allow the overlay material to center itself. Align the edges of the overlay on the take-up spool.
	The laminator cartridge is damaged.	Replace the laminator cartridge.
The patch has wavy lines along the length of the card.	The temperature for applying the overlay is set too high.	Decrease the laminator temperature setting. Refer to the Printer Manager <a href="#">“Laminate Type”</a> section of the printer’s <i>Installation and Administrator’s Guide</i> .
	The heated roller is damaged.	Power down the system. Contact your service provider for assistance.
	The card has features, such as a smart card chip, that interfere with application of the overlay.	Use the correct patch material for your card type. Refer to <a href="#">“Laminator Overlay Materials”</a> on page A-6 for a description of overlay types.

Problem	Probable Cause	Solution
The patch shows opaque areas at the leading edge of the card.	The temperature for applying the overlay is too high.	Decrease the laminator temperature setting. Refer to the Printer Manager "Laminate Type" section of the printer's <i>Installation and Administrator's Guide</i> . If the problem continues to occur, contact your service provider for assistance.
The patch extends beyond one of the short edges of the card.	There is slack in the overlay material.	Process another card to allow the overlay material to reset itself.
	The overlay material is wound incorrectly on the take-up spool.	Remove the laminator cartridge and turn the take-up spool clockwise several turns.
	The card or overlay registration settings are not correct.	Contact your service provider for assistance.
The patch is missing from the finished card.	The supply spool is not positioned correctly in the cartridge.	Make sure that the overlay is loaded correctly. Refer to " <a href="#">Load Laminator Overlay Material</a> " on <a href="#">page A-8</a> .
	The overlay was moved on the spool and the patch was used previously.	Advance the overlay past the used area. If the problem continues to occur, contact your service provider.
	The Card Printer Driver Laminate card setting was set to Do not apply.	Change the Laminate card setting to apply the overlay. Refer to the printer's <i>Driver Guide</i> for information about specifying lamination settings.

## Topcoat Appearance Problems

Problem	Probable Cause	Solution
There are scratches in the topcoat.	The inside of the printer is dirty.	Clean the printer. Refer to " <a href="#">Run a Cleaning Card</a> " on <a href="#">page 36</a> .
	The supplies have debris on them.	Store and handle supplies carefully. Keep supplies in the original packaging until you are ready to use them.

Problem	Probable Cause	Solution
There are repeating marks in the topcoat.	The heated roller is dirty.	Clean the laminator. Refer to <a href="#">“Clean the Laminator”</a> on <a href="#">page A-12</a> . If the problem continues to occur, contact your service provider.
The holographic topcoat shows irregular darker areas.	The temperature for applying the holographic topcoat is too high.	Decrease the laminator temperature for the overlay material. Refer to the Printer Manager “Laminate Type” section of the printer’s <i>Installation and Administrator’s Guide</i> .
There are particles of holographic topcoat beyond the trailing edge of the card.	The temperature for applying the holographic topcoat is too high.	<ul style="list-style-type: none"> <li>• Topcoat particles, or flash, can become attached to the card. Try to brush off the particles.</li> <li>• Clean the laminator. Refer to <a href="#">“Clean the Laminator”</a> on <a href="#">page A-12</a>.</li> <li>• Decrease the laminator temperature for the overlay material. Refer to the Printer Manager “Laminate Type” section of the printer’s <i>Installation and Administrator’s Guide</i>.</li> </ul> <p><b>Note:</b> Reducing the temperature can reduce the number of particles, but does not eliminate them.</p>
The topcoat shows wavy lines along the length of the card.	The temperature for applying the topcoat is too high.	Decrease the laminator temperature for the overlay material. Refer to the Printer Manager “Laminate Type” section of the printer’s <i>Installation and Administrator’s Guide</i> .
The topcoat shows opaque areas along a short edge of the card.	The temperature for applying the topcoat is too high.	Decrease the laminator temperature for the overlay material. Refer to the Printer Manager “Laminate Type” section of the printer’s <i>Installation and Administrator’s Guide</i> . If the problem continues to occur, contact your service provider for assistance.
The topcoat is spotty, especially on the leading edge of the card.	The overlay material is wound in the wrong direction on the take-up spool.	Process another card to allow the overlay material to reset itself. If it doesn’t, remove the cartridge and turn the take-up spool clockwise several turns.

Problem	Probable Cause	Solution
The hologram of the topcoat doesn't appear on the card.	The Card Printer Driver Laminate card setting is set to Do not apply.	Change the Laminate card setting to apply the overlay. Refer to the printer's <i>Driver Guide</i> for information about specifying lamination settings.
	Clear topcoat is installed in the cartridge.	Remove the cartridge and change the overlay to the correct type.
	The overlay material is wound in the wrong direction on the take-up spool.	Process another card to allow the overlay material to reset itself. If it doesn't, remove the cartridge and turn the take-up spool clockwise several turns.
	The overlay is not loaded correctly in the cartridge.	Remove the cartridge and reload the overlay. Refer to " <a href="#">Load Laminator Overlay Material</a> " on <a href="#">page A-8</a> .
A long edge of the topcoat doesn't stick to the card.	The temperature of the heated roller is too low	Increase the laminator temperature for the overlay. Refer to the Printer Manager "Laminate Type" section of the printer's <i>Installation and Administrator's Guide</i> .
	Print ribbon that includes a topcoat (T) panel is loaded in the printer.	Change the print ribbon to one that doesn't include a T panel.
	The cards do not meet specifications.	Use a different supply of cards.
	The overlay material was wound in the wrong direction on the take-up spool.	Process another card to allow the overlay material to reset itself. If it doesn't, remove the cartridge and turn the take-up spool clockwise several turns.
	There is debris on the heated roller.	Process several cards to see if the problem corrects itself. If it doesn't, clean the laminator. Refer to " <a href="#">Clean the Laminator</a> " on <a href="#">page A-12</a> .

## Use Advanced Troubleshooting Tools

Printer Manager provides access to card design settings and additional troubleshooting tools. Printer Manager also allows you to perform advanced troubleshooting with the guidance of your service provider. Refer to "Printer Manager" in the printer's *Installation and Administrator's Guide* for more information.

# Card Jams

A card jam occurs when the card does not reach the proper position for the next action, such as printing or ejecting the card.

You usually can resolve the error by pressing the **USER** button so that the printer displays **Ready**. If the error persists, do the following to remove the card from the printer.

1. Unlock the printer, if necessary, and open the printer cover.
2. Remove the print ribbon cartridge.
3. Turn the manual advance knob to move the jammed card until it is accessible from the rollers or exits into the output hopper.
4. Remove the card.
5. Replace the ribbon cartridge and close the printer cover.
6. Lock the printer, if necessary.
7. Press the **USER** button on the printer or click **Retry** in the PC message.

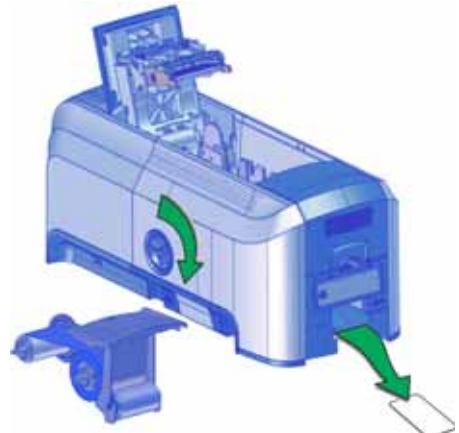

## HINTS & TIPS

Check the ribbon to make sure that it is not torn. Refer to [“Repair a Broken Ribbon”](#) on page 65 and [“109: Print ribbon problem”](#) on page 73 to repair or replace the ribbon, if needed.



For laminator card jams, refer to [“Clear a Laminator Card Jam”](#) on page A-11.

# Repair a Broken Ribbon

A ribbon can break if the power applied by the printhead is too high. Do the following to repair a broken ribbon.

1. Open the printer and remove the print ribbon cartridge.



Do not remove the used ribbon from the take-up spool. This may cause printing issues.

2. Trim the ends of the broken ribbon evenly.
3. Align the ends of the broken ribbon and apply adhesive tape to secure them.
4. Turn the take-up spool counterclockwise until the mended portion is wound around the spool two or three turns.
5. Reinstall the print ribbon cartridge in the printer.
6. Close the printer.

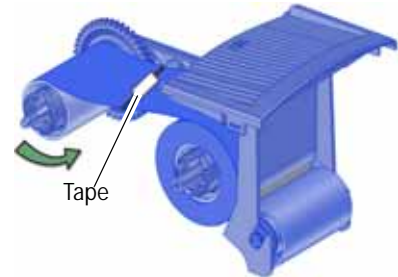

## Messages and Conditions

When the printer cannot process the card sent, it issues a condition. Conditions display on the LCD panel on the front panel of the printer. If you use the XPS Card Printer Driver, the printer driver also displays the condition as a message on the PC. In a shared printer environment, messages can differ slightly from the messages and conditions described in this section.

- [Messages on the Printer LCD](#)
- [Messages from the XPS Card Printer Driver on the PC on page 69](#)
- [Messages from Printer Manager on page 69](#)
- [Other Messages on page 69](#)

### Messages on the Printer LCD

All messages are associated with a print job. The printer issues messages that focus on recovering from problems.

- The printer displays a message number and a short description for each message.
- If more than one message was issued, the next message displays after you correct the problem and press the USER button.
- The lights on the front panel flash while messages display on the LCD panel.



## Printer Messages

No.	LCD Message	User Light	Supply Light	Card Light
–	Close and lock doors	Color Cycle	Off	Off
100	Request not supported	Amber Flash	Off	Off
101	Job could not complete	Amber Flash	Off	Off
102	Card not in position	Off	Off	Amber Flash
103	Printer problem	Amber Flash	Off	Off
104	Critical problem	Amber Flash	Amber Flash	Amber Flash
105	Magstripe data error	Amber Flash	Off	Off
106	Magstripe data not found	Off	Off	Amber Flash
107	Magstripe read data error	Off	Off	Amber Flash
108	Magstripe read no data	Off	Off	Amber Flash
109	Print ribbon problem	Off	Amber Flash	Off
110	Print ribbon out or missing	Off	Amber Flash	Off
111	Card not picked	Off	Off	Amber Flash
112	Card hopper empty	Off	Off	Amber Flash
113	Close cover to continue	Amber Flash	Off	Off
114	Cover opened during job	Amber Flash	Off	Off
116	Magstripe not available	Amber Flash	Off	Off
117	Reader not available	Amber Flash	Off	Off
118	Print ribbon type problem	Off	Amber Flash	Off
119	Print ribbon not supported	Off	Amber Flash	Off
120	User paused the printer	Amber Flash	Off	Off
121	Print ribbon not identified	Off	Amber Flash	Off
122	Magstripe format problem	Amber Flash	Off	Off

No.	LCD Message	User Light	Supply Light	Card Light
123	Insert new card side 1 up	Amber Flash	Off	Off
124	Insert same card side 2 up	Amber Flash	Off	Off
149	Option not installed	Amber Flash	Off	Off
150	Print while unlocked	Amber Flash	Off	Off
151	Failed to lock	Amber Flash	Off	Off
152	Insert new card side 2 up	Amber Flash	Off	Off
153	Insert same card side 2 up	Amber Flash	Off	Off
170	Insert new card side 1 up	Amber Flash	Off	Off
171	Insert same card side 1 up	Amber Flash	Off	Off
172	Insert cleaning card	Off	Off	Amber Flash
173	Improper shutdown	Amber Flash	Off	Off
224	Supply region not valid	Off	Amber Flash	Off
245	Configuration error	Green Flash	Off	Off

## Laminator Messages

No.	LCD Message	User Light	Supply Light	Card Light	Laminator Light
177	Laminator not available	Green Flash	Off	Off	
196	Laminator error critical	Green Flash	Green Flash	Green Flash	Red Flash
197	Laminator entry card problem	Off	Off	Green Flash	Red Flash
198	L1 area card problem	Off	Off	Green Flash	Red Flash
199	L2 area card problem	Off	Off	Green Flash	Red Flash
200	Laminator exit card problem	Off	Off	Green Flash	Red Flash
201	L1 supply problem	Off	Green Flash	Off	Red Flash

No.	LCD Message	User Light	Supply Light	Card Light	Laminator Light
202	L1 supply out or missing	Off	Green Flash	Off	Red Flash
203	L1 supply type problem	Off	Green Flash	Off	Red Flash
204	L1 supply not supported	Off	Green Flash	Off	Red Flash
205	L1 supply not identified	Off	Green Flash	Off	Red Flash
206	L2 supply problem	Off	Green Flash	Off	Red Flash
207	L2 supply out or missing	Off	Green Flash	Off	Red Flash
208	L2 supply type problem	Off	Green Flash	Off	Red Flash
209	L2 supply not supported	Off	Green Flash	Off	Red Flash
210	L2 supply not identified	Off	Green Flash	Off	Red Flash
211	L1 heater problem	Green Flash	Off	Off	Red Flash
212	L2 heater problem	Green Flash	Off	Off	Red Flash
213	L1 heater sensor problem	Green Flash	Off	Off	Red Flash
214	L2 heater sensor problem	Green Flash	Off	Off	Red Flash
215	L1 heater roller problem	Green Flash	Off	Off	Red Flash
216	L2 heater roller problem	Green Flash	Off	Off	Red Flash
217	Debow problem	Green Flash	Off	Off	Red Flash
218	Impresser problem	Green Flash	Off	Off	Red Flash
219	Impresser sensor problem	Green Flash	Off	Off	Red Flash
220	Impresser heater problem	Green Flash	Off	Off	Red Flash
221	Bar code scanner problem	Green Flash	Off	Off	Red Flash
222	Firmware version mismatch	Green Flash	Green Flash	Green Flash	Red Flash
223	Laminator system mismatch	Green Flash	Green Flash	Green Flash	Red Flash

## Messages from the XPS Card Printer Driver on the PC

- The Card Printer Driver displays the same messages as those on the printer LCD panel. The messages that display on the PC provide additional information about the condition that caused the message and contain recovery instructions. Click the appropriate button to clear the message.
- Messages display on the PC that sent the card print job.
- If you cancel a job at the printer, the message is removed from the PC. Any additional messages for the canceled job (for example, for a broken ribbon) do not display on the PC.
- Messages can display in the background, behind the application sending the card. On some operating systems, the message displays in the status bar. Click the blinking Explorer (folder) icon in the status bar to open the message.
- If more than one message was issued, the next message displays after you close the current message.
- If there is more than one card printer installed on the PC, messages display one at a time. The title bar of each message shows the printer name.
- If there is more than one card printer installed on the PC and each has issued errors, the printer driver displays the messages received, even if you cleared the error at the printer.
- The Card Printer Driver can issue messages that do not display on the printer LCD panel. Refer to [“Driver-Only Messages” on page 86](#) and [“Driver SDK Messages” on page 88](#) for a list of these messages.

## Messages from Printer Manager

Printer Manager issues messages that display in the browser window. Follow the instructions in the message to continue working with the printer. Refer to “Printer Manager” in your printer’s *Installation and Administrator’s Guide*.

## Other Messages

- The card production application you use also may issue messages.
- Other printers can cause messages if more than one model of card printer is installed.

## Respond to Messages

You can respond to printer messages using the printer front panel buttons or by clicking the appropriate response in the message displayed by the Card Printer Driver on the PC.

## Printer Messages

The following messages display on the printer LCD panel and in a message on the PC that issued the card print job when you use the Card Printer Driver. Use the recovery instructions to respond to the message.



The messages that display are determined by the printer model and the options installed on the printer. The messages described in the following sections may not display on all printers.

### Close and lock doors

A secure door is physically unlocked on the system.

1. Gently try to open all secure doors on the system.
2. Close any open door and lock the printer and/or embosser using the key.

### 100: Request not supported

The printer does not support the personalization being requested for the card. The card will be canceled.

Change the card data to match the printer's options and settings, or print to a printer that is configured to support the personalization being requested.

Press the USER button on the printer, or click **OK** on the PC to clear the message.

### 101: Job could not complete

The card took too much time to complete.

The card will be canceled.

Press the USER button on the printer, or click **OK** on the PC to clear the message.

## 102: Card not in position

The card is not positioned in the printer correctly.

1. Open the printer and remove the ribbon cartridge.
2. Turn the knob to remove the card.
3. Replace the ribbon cartridge and close the printer.

Press the USER button on the printer to clear the message. On the PC, click **Retry**, or click **Cancel** to cancel the card.

## 103: Printer problem

The printer had an error. The card will be canceled.

1. Press the printer POWER button to power off the printer.
2. Press the POWER button again to power on the printer.

Click **OK** on the PC to clear the message.

## 104: Critical problem

The printer had a serious error. The card will be canceled.

1. Press the printer POWER button to power off the printer.
2. Request service.

The system must remain powered off.

Click **OK** on the PC to clear the message.

## 105: Magstripe data error

The printer failed to verify that the correct magnetic stripe data was written on the card.

1. Make sure that you are using magnetic stripe cards that match the printer settings.
2. Make sure that the cards are placed in the printer correctly.

Press the USER button on the printer to clear the message. On the PC, click **Retry**, or click **Cancel** to cancel the card.

### HINTS & TIPS

- The card might have been turned the wrong way. A diagram inside the input hopper shows the correct orientation.
- The card might not have a magnetic stripe.

## 106: Magstripe data not found

The printer did not find magnetic stripe data on card.

1. Make sure that you are using magnetic stripe cards that match the printer settings.
2. Make sure that the cards are placed in the printer correctly.

Press the **USER** button on the printer to clear the message. On the PC, click **Retry**, or click **Cancel** to cancel the card.

### HINTS & TIPS

- The card might not match printer settings or the data sent.
- Ask the system administrator to verify that the card, the data, and the printer settings match.

## 107: Magstripe read data error

The printer failed to read the magnetic stripe data from the card. The card will be canceled.

1. Make sure that you are using magnetic stripe cards that match the printer settings.
2. Make sure that the cards are placed in the printer correctly.

Press the **USER** button on the printer to send a new card to the printer. On the PC, click **OK** to clear the message.

### HINTS & TIPS

- The data might use a different format than the current printer setting.
- Ask the system administrator to verify that the card, data, and printer settings match.

## 108: Magstripe read no data

The printer did not find any magnetic stripe data on card. The card will be canceled.

1. Make sure that you are using magnetic stripe cards that match the printer settings.
2. Make sure that the cards are placed in the printer correctly.

Press the **USER** button on the printer to send a new card to the printer. On the PC, click **OK** to clear the message.

### HINTS & TIPS

- The card might have been turned the wrong way. A diagram inside the input hopper shows the correct orientation.
- The card might not have a magnetic stripe.

## 109: Print ribbon problem

The print ribbon is not moving properly.

1. Open the printer and remove the ribbon cartridge.
2. Reposition, repair, or replace the ribbon and advance the repaired area one full turn.
3. Replace the ribbon cartridge and close the printer.

Press the USER button on the printer to clear the message and send a new card to the printer. On the PC, click **Retry**, or click **Cancel** to cancel the card.

### HINTS & TIPS

- Remove any debris from the print area.
- If a card is in the printer, turn the manual advance knob to move the card so that the printer can eject it.

## 110: Print ribbon out or missing

The printer does not have usable ribbon. To complete the current card:

1. Open the printer and remove the ribbon cartridge.
2. Install a new ribbon and cleaning roller.
3. Replace the cartridge and close the printer.

Press the USER button on the printer to clear the message. On the PC, click **OK**, or click **Cancel** to cancel the card.

### HINTS & TIPS

Used ribbon has negative images of printed data. To keep the data confidential, follow your company policy to discard used ribbon.

## 111: Card not picked

The printer did not pick a card. To complete the current card:

For printers with an input hopper, open the input hopper, add or reposition cards, and close the hopper.

For printers with a single-card feed, push the card in until the printer picks it.

Press the USER button on the printer to clear the message. On the PC, click **OK**, or click **Cancel** to cancel the card.



## 112: Card hopper empty

The printer did not detect cards in the input hopper.

Add cards to the input hopper.

Press the **USER** button on the printer to clear the message. On the PC, click **OK**, or click **Cancel** to cancel the card.

## 113: Close cover to continue

The cover is open or the print ribbon cartridge is missing.

Confirm that the print ribbon cartridge is installed and then close the cover.

Press the **USER** button on the printer to clear the message. On the PC, click **OK**, or click **Cancel** to cancel the card.

### **HINTS & TIPS**

- Make sure that the ribbon cartridge is installed properly with the cartridge handle even with the edges of the printer.
- Press down on the cover ridges to make sure that the cover latches completely on both sides.
- All access doors must be closed to process cards. Unlock, open, and close all printer doors to make sure they are closed completely.
- Lock the system.

## 114: Cover opened during job

The printer cover was opened while printing.

Push down on the cover to latch it.

Press the **USER** button on the printer to clear the message. On the PC, click **Retry**, or click **Cancel** to cancel the card.

### **HINTS & TIPS**

- Make sure that the ribbon cartridge is installed properly with the handle even with the edges of the printer.
- Press down on the cover ridges to make sure that the cover latches completely on both sides.
- All access doors must be closed to process cards. Unlock, open, and close all printer doors to make sure they are closed completely.
- Lock the system.

## 116: Magstripe not available

The printer does not have a magnetic stripe option. The card will be canceled.

Remove magnetic stripe data from the card or use a printer that has a magnetic stripe option installed.

Press the USER button on the printer to clear the message. On the PC, click **OK** to clear the message.

### HINTS & TIPS

- Look at the printer configuration label inside the printer. If the label shows either "M" or "J", the system has a magnetic stripe option that is not working. Request service.
- To process the card without magnetic stripe processing, remove the magnetic stripe data from the card design and send it again.

To remove magnetic stripe data, you or your system administrator may need to:

- Clear a check box in the card production application.
- Change the font from Mag Trackx XPS Card Printer to a printable font such as Arial, Verdana, or Calibri. Refer to "Magnetic Stripe Fonts" in your printer's *Driver Guide*.

## 117: Reader not available

The printer does not support the personalization being requested for the card. The card will be canceled.

Change the card data to match the printer's options and settings or print to a printer that is configured to support the personalization being requested.

Press the USER button on the printer, or click **OK** on the PC, to clear the message.

### HINTS & TIPS

To remove the reader request, you or your system administrator may need to clear a check box in the card production application.

### 118: Print ribbon type problem

The printer cannot use the ribbon installed. The card will be canceled.

Use ribbon designed for this printer.

Press the USER button on the printer, or click **OK** on the PC, to clear the message.

#### **HINTS & TIPS**

- Purchase ribbon from your dealer or authorized reseller.
- Check the Datacard website for updated firmware that supports new ribbon types.

### 119: Print ribbon not supported

The printer cannot use the ribbon installed. The card will be canceled.

Press the USER button on the printer, or click **OK** on the PC, to clear the message.

#### **HINTS & TIPS**

- Purchase ribbon from your dealer or authorized reseller.
- Check the Datacard website for updated firmware that supports new ribbon types.

### 120: User paused the printer

The printer was paused while printing.

To complete the current card press the printer's USER button.

On the PC, click **OK** to clear the message and complete the current card, or click **Cancel** to cancel the card.

#### **HINTS & TIPS**

- If the user pressed the USER button for several seconds, the card has been canceled.
- If this message occurs often, ask your system administrator to set the button sensitivity to a lower value.

### 121: Print ribbon not identified

The printer cannot use the ribbon installed. The card will be canceled.

Use ribbon designed for this printer.

Press the USER button on the printer, or click **OK** on the PC, to clear the message.

#### **HINTS & TIPS**

Ask your dealer or authorized reseller for a replacement ribbon.

## 122: Magstripe format problem

The magnetic stripe data sent does not match the format set in the printer. The card will be canceled.

Press the User button on the printer, or click **OK** on the PC, to clear the message.

## 123: Insert new card side 1 up

1. Insert a new card in the printer with side 1 facing up.
2. If the card is not immediately picked, press the printer's USER button or click **OK**.

Click **Cancel** on the PC if you want to cancel the card.

## 124: Insert same card side 2 up

1. Take the card from the printer.
2. Turn the card over end to end so side 2 is facing up.
3. Insert the card in the printer.
4. If the card is not immediately picked, press the printer's USER button or click **OK**.

Click **Cancel** on the PC if you want to cancel the card.

## 149: Option not installed

The printer does not support the personalization being requested for the card. The card will be canceled.

Change the card data to match the printer's options and settings, or print to a printer that is configured to support the personalization being requested.

Press the User button on the printer, or click **OK** on the PC, to clear the message.

### **HINTS & TIPS**

In the card format, don't include references to hardware that cannot be accessed by the system. For more information, refer to your ID software documentation or ask your system administrator.

## 150: Print while unlocked

The printer is unlocked. The card will be canceled.

Make sure that all access doors are closed securely and locked.

Click **OK** on the PC to clear the message.

### 151: Failed to lock

An attempt to lock the printer failed. The card will be canceled.

1. Make sure that all access doors are closed securely.
2. Try locking the printer again.

Click **OK** on the PC to clear the message.

#### **HINTS & TIPS**

Make sure that the reject tray is installed properly before locking the printer.

### 152: Insert new card side 2 up

1. Turn a new card over end to end so side 2 is facing up.
2. Insert the card in the printer.
3. If the card is not immediately picked, press the printer's **USER** button or click **OK**.

Click **Cancel** on the PC if you want to cancel the card.

### 153: Insert same card side 2 up

1. Take the card from the printer and turn it over end to end so side 2 is facing up.
2. Insert the card in the printer.
3. If the card is not immediately picked, press the printer's **USER** button or click **OK**.

Click **Cancel** on the PC if you want to cancel the card.

### 170: Insert new card side 1 up

1. Insert a new card in the printer with side 1 facing up.
2. If the card is not immediately picked, press the printer's **USER** button or click **OK**.

Click **Cancel** on the PC if you want to cancel the card.

### 171: Insert same card side 1 up

1. Take the card from the printer and turn it over end to end so side 1 is facing up.
2. Insert the card in the printer.
3. If the card is not immediately picked, press the printer's **USER** button or click **OK**.

Click **Cancel** on the PC if you want to cancel the card.

#### 172: Insert cleaning card

1. Insert cleaning card.
2. If the card is not immediately picked, press the printer's USER button or click **OK**.

Click **Cancel** on the PC to cancel the cleaning card.

#### 173: Improper shutdown

Always use the power button to power off the printer.

Press and hold the USER button to set the printer to **Ready**.

Click **OK** on the PC to clear the message.

#### 224: Supply region not valid

The printer cannot use the supply installed. The card will be canceled.

Use a supply with the correct code for your region.

Click **OK** on the PC to clear the message.

#### 245: Configuration error

The configuration is not compatible with the printer model. The printer cannot print cards until the configuration issue is corrected. Contact your service provider for assistance.

## Laminator Messages

The following messages display on the printer LCD panel when you are using a laminating system. They also display in a message on the PC that issued the card print job.

### 177: Laminator not available

The printer and laminator cannot communicate. The card will be canceled.

1. Make sure the data cable from the laminator to the printer is securely plugged in.
2. Press the printer **POWER** button to power off the system.
3. Press the **POWER** button again to power on the system.

On the PC, click **Retry**, or click **Cancel** to cancel the card.

### 196: Laminator error critical

The laminator has encountered a critical error. The card will be canceled.

1. Press the printer **POWER** button to power off the system.
2. Request service. The system must remain powered off.

On the PC, click **OK** to clear the message.

### 197: Laminator entry card problem

The card is not where it should be in the laminator.

1. Open the laminator.
2. Turn the knob to remove the card.
3. Close the laminator.

On the PC, click **Retry**, or click **Cancel** to cancel the card.

### 198: L1 area card problem

The card is not where it should be in the laminator.

1. Open the laminator and remove the L1 supply cartridge.
2. Turn the knob to remove the card.
3. Replace the supply cartridge and close the laminator.

On the PC, click **Retry**, or click **Cancel** to cancel the card.

### 199: L2 area card problem

The card is not where it should be in the laminator.

1. Open the laminator and remove the L2 supply cartridge.
2. Turn the knob to remove the card.
3. Replace the supply cartridge and close the laminator.

On the PC, click **Retry**, or click **Cancel** to cancel the card.

### 200: Laminator exit card problem

The card is not where it should be in the laminator.

1. Open the laminator.
2. Turn the knob to remove the card.
3. Close the laminator.

On the PC, click **Retry**, or click **Cancel** to cancel the card.

### 201: L1 supply problem

The L1 supply is not moving properly. To try another card:

1. Open the laminator and remove the L1 cartridge.
2. Reposition, repair, or replace the supply and advance the repaired area one full turn.
3. Replace the cartridge and close the laminator.

On the PC, click **Retry**, or click **Cancel** to cancel the card.

### 202: L1 supply out or missing

The laminator does not have usable supplies.

1. Open the laminator.
2. Replace the supply.
3. Close the laminator.

On the PC, click **OK**, or click **Cancel** to cancel the card.

### 203: L1 supply type problem

The laminator cannot use the supply installed.

Use supplies designed for this laminator.

On the PC, click **Retry**, or click **Cancel** to cancel the card.



#### 204: L1 supply not supported

The laminator cannot use the supply installed.

Use supplies designed for this laminator.

On the PC, click **Retry**, or click **Cancel** to cancel the card.

#### 205: L1 supply not identified

The laminator cannot use the supply installed.

Use supplies designed for this laminator.

On the PC, click **Retry**, or click **Cancel** to cancel the card.

#### 206: L2 supply problem

The L2 supply is not moving properly. To try another card:

1. Open the laminator and remove the L2 cartridge.
2. Reposition, repair, or replace the supply and advance the repaired area one full turn.
3. Replace the cartridge and close the laminator.

On the PC, click **Retry**, or click **Cancel** to cancel the card.

#### 207: L2 supply out or missing

The laminator does not have usable supplies.

1. Open the laminator.
2. Replace the supply.
3. Close the laminator.

On the PC, click **OK**, or click **Cancel** to cancel the card.

#### 208: L2 supply type problem

The laminator cannot use the supply installed.

Use supplies designed for this laminator.

On the PC, click **Retry**, or click **Cancel** to cancel the card.

#### 209: L2 supply not supported

The laminator cannot use the supply installed.

Use supplies designed for this laminator.

On the PC, click **Retry**, or click **Cancel** to cancel the card.

#### 210: L2 supply not identified

The laminator cannot use the supply installed.

Use supplies designed for this laminator.

On the PC, click **Retry**, or click **Cancel** to cancel the card.

#### 211: L1 heater problem

The laminator has encountered a critical error. The card will be canceled.

1. Press the printer POWER button to power off the system.
2. Request service. The system must remain powered off.

On the PC, click **OK** to clear the message.

#### 212: L2 heater problem

The laminator has encountered a critical error. The card will be canceled.

1. Press the printer POWER button to power off the system.
2. Request service. The system must remain powered off.

On the PC, click **OK** to clear the message.

#### 213: L1 heater sensor problem

The laminator has encountered a critical error. The card will be canceled.

1. Press the printer POWER button to power off the system.
2. Request service. The system must remain powered off.

On the PC, click **OK** to clear the message.

#### 214: L2 heater sensor problem

The laminator has encountered a critical error. The card will be canceled.

1. Press the printer POWER button to power off the system.
2. Request service. The system must remain powered off.

On the PC, click **OK** to clear the message.

### 215: L1 heater roller problem

The laminator has encountered a critical error. The card will be canceled.

1. Press the printer **POWER** button to power off the system.
2. Request service. The system must remain powered off.

On the PC, click **OK** to clear the message.

### 216: L2 heater roller problem

The laminator has encountered a critical error. The card will be canceled.

1. Press the printer **POWER** button to power off the system.
2. Request service. The system must remain powered off.

On the PC, click **OK** to clear the message.

### 217: Debow problem

The laminator has encountered an error in the debow area.

1. Remove the card.
2. Press the printer **POWER** button to power off the system.
3. Press the printer **POWER** button again to power on the system.
4. If the problem occurs again, request service.

On the PC, click **Retry**, or click **Cancel** to cancel the card.

### 218: Impresser problem

The laminator has encountered a critical error. The card will be canceled.

1. Press the printer **POWER** button to power off the system.
2. Request service. The system must remain powered off.

On the PC, click **OK** to clear the message.

### 219: Impresser sensor problem

The laminator has encountered a critical error. The card will be canceled.

1. Press the printer **POWER** button to power off the system.
2. Request service. The system must remain powered off.

On the PC, click **OK** to clear the message.

## 220: Impresser heater problem

The laminator has encountered a critical error. The card will be canceled.

1. Press the printer POWER button to power off the system.
2. Request service. The system must remain powered off.

On the PC, click **OK** to clear the message.

## 221: Bar code scanner problem

The bar code scanner cannot read the bar code on the overlay. This can indicate a scanner problem, an unreadable bar code, or an incorrect L1 cartridge.

Try the card again.

If the problem occurs again, request service.

On the PC, click **OK** to clear the message.

## 222: Firmware version mismatch

The printer and laminator firmware versions are not compatible. The system cannot laminate cards until the firmware has been updated.

Update both the printer and laminator to the latest firmware versions.

## 223: Laminator system mismatch

The printer and laminator are not compatible.

The laminator is not supported by your printer model. Contact your service provider for the correct laminator model.

## Driver-Only Messages

The following messages are issued by the Card Printer Driver and display on the PC that sent the card print job. These messages do not display on the printer LCD panel.

### 500: The printer is not available

The computer cannot communicate with the printer. To complete the current card:

1. Make sure that the printer is powered on and in the **Ready** state.
2. Make sure the printer is connected to the computer using a USB or network cable, but not both.

When the printer is ready, click **OK**.

Click **Cancel** if you want to cancel the card

### 501: The printer connection was lost

The computer lost communications with the printer during printing. The card will be canceled.

1. Make sure the printer is powered on.
2. Make sure the printer connection to the computer is secure.

Click **OK** to clear the message.

### 502: The card data is missing or is not usable

The printer driver has detected invalid or missing data. The card will be canceled.

Make sure the data being sent is formatted properly and matches the options and settings in the printer.

Click **OK** to clear the message.

### 504: The card data is missing or is not usable

The printer driver has detected invalid or missing data. The card will be canceled.

Make sure the data being sent is formatted properly and matches the options and settings in the printer.

Click **OK** to clear the message.

#### 505: USB communication issue

An important driver component is not running. The card will be canceled.

1. Restart the computer. The component should start automatically.
2. If this message is displayed after restarting, notify your printer support contact.

Click **OK** to clear the message.

#### 506: A card is currently processing

The printer is busy processing an interactive job. The card will be canceled.

Wait until the current card is complete and then try again.

Click **OK** to clear the message.

#### 507: The printer is unlocked

The printer must be locked to print.

To complete the current card make sure that all access doors are closed securely and locked.

Click **OK** to clear the message, or click **Cancel** to cancel the card.

#### 508: The printer is shutting down

The printer is shutting down or resetting. The card will be canceled.

When printer is powered back on, try again.

Click **OK** to clear the message.

#### 509: The printer is offline or suspended

The printer must be online to print.

To complete the current card press the printer's **USER** button until the printer returns to the **Ready** state.

Click **OK** to clear the message, or click **Cancel** to cancel the card.

#### 510: The printer is unlocked

The printer must be locked to resume printing.

Make sure that all access doors are closed securely and locked.

Click **OK** to clear the message, or click **Cancel** to cancel the card.

## Driver SDK Messages

The following messages are issued when you use the Card Printer Driver Software Development Kit (SDK) to define your card printing. The messages are returned by the SDK to the application that sent the print job. These messages do not display on the printer LCD panel or on the PC that sent the job.



The messages returned to the SDK are determined by the printer model and the options installed on the printer. The following messages may not apply to all printers.

511: Cannot lock or unlock the printer. Locks are not installed.

**Severity:** Critical

512: Cannot lock or unlock the printer. The password is incorrect or invalid.

**Severity:** Critical

513: Cannot lock or unlock the printer. The printer is busy.

**Severity:** Notice

514: Cannot lock or unlock the printer. The cover is open.

**Severity:** Notice

515: Failed to lock or unlock the printer. The locks did not function.

**Severity:** Critical

516: Timeout expired before bar code could be read.

**Severity:** Notice

517: Wrong printer job ID.

**Severity:** Critical



# Appendix A: CLM Laminator

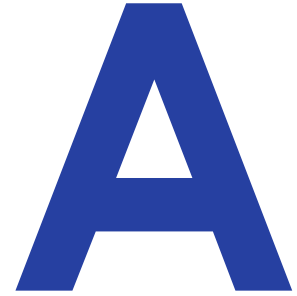

This appendix provides information about the optional CLM laminator that you can add to your system at the time of purchase or later, as a field upgrade.

---

## About the Laminator System

A laminator system consists of a CD800 card printer and a CLM laminator. The system can print cards and apply an overlay material on the front and back of the card for increased durability and security. Using an overlay material with holographic or other transparent images also improves the security of the card. These materials are tamper evident, making it difficult to reproduce or modify a card.



Your laminator may look different from the one shown in the illustrations, based on the options installed. The information described in this appendix applies to all CLM laminators.

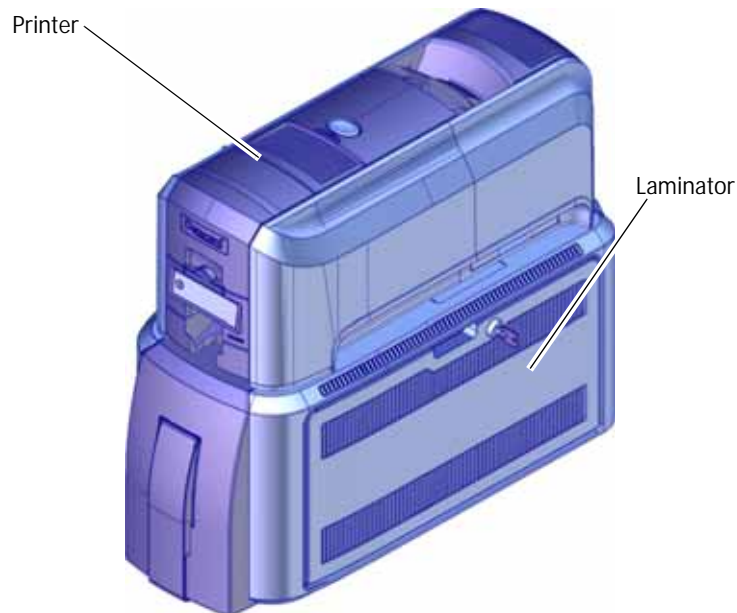



# Outside the Laminator

Use the following information to become familiar with the laminator.

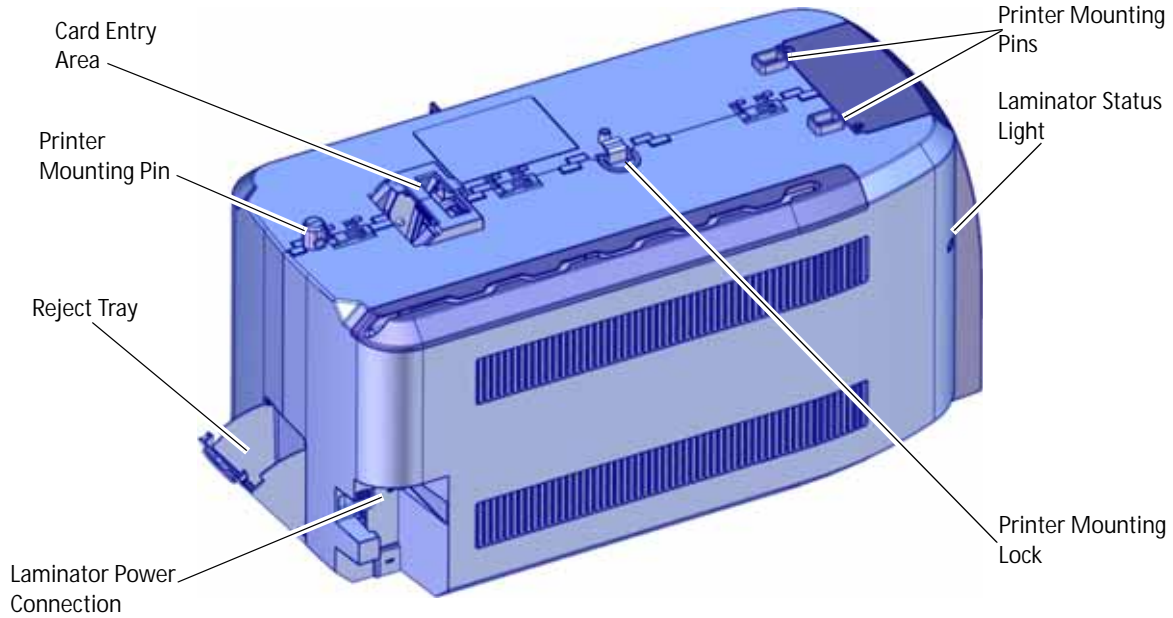

## Laminator Back and Left Side



<b>Printer Mounting Pins</b>	The pins align the printer with the laminator.
<b>Printer Mounting Lock</b>	The lock secures the printer to the laminator.
<b>Laminator Status Light</b>	The light shows the status of the laminator. Refer to <a href="#">“Laminator Status Light”</a> on page A-3.
<b>Card Entry Area</b>	The card entry area receives the card from the printer and places it into position for laminating.
<b>Reject Tray</b>	Unfinished cards or cards not processed properly are placed in the reject tray.
<b>Laminator Power Connection</b>	The power connection provides a plug-in connector for the laminator power supply.

### Laminator Status Light

The status light shows the status of the laminator:

Ready	Solid green	
Busy	Blinking green	
Idle/Sleeping	Solid blue	
Heating	Blinking blue	
Error	Blinking red	

### Laminator Front and Right Side

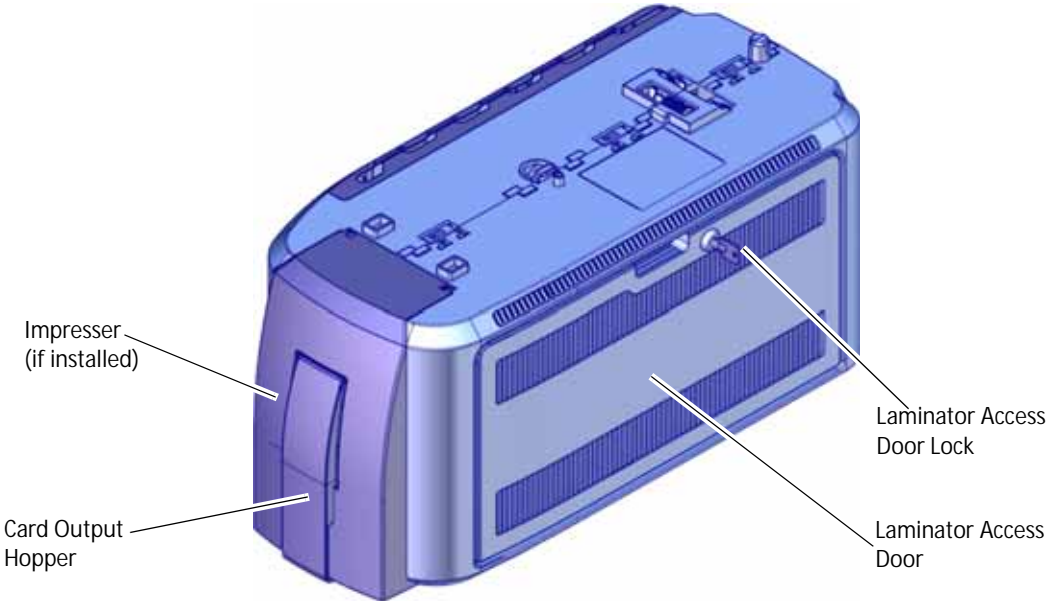

- Card Output Hopper**      The card output hopper holds up to 100 completed cards.
- Laminator Access Door**      The access door provides access to the laminator supplies.
- Laminator Access Door Lock**      The optional lock provides secure access to the laminator.  
**Note:** If the laminator has a lock, the printer also must have a lock.
- Impresser**      The optional impresser is located inside the laminator just before the card exit slot.

# Inside the Laminator

The CLM laminator has one standard laminator, in the L1 position, with an optional second laminator in the L2 position. The laminators apply topcoat or patch overlay material to the card. Topcoat is a continuous film and patch is a die-cut polyester shape. Both laminators can apply either overlay type. Refer to [“Laminator Overlay Materials”](#) on page A-6.

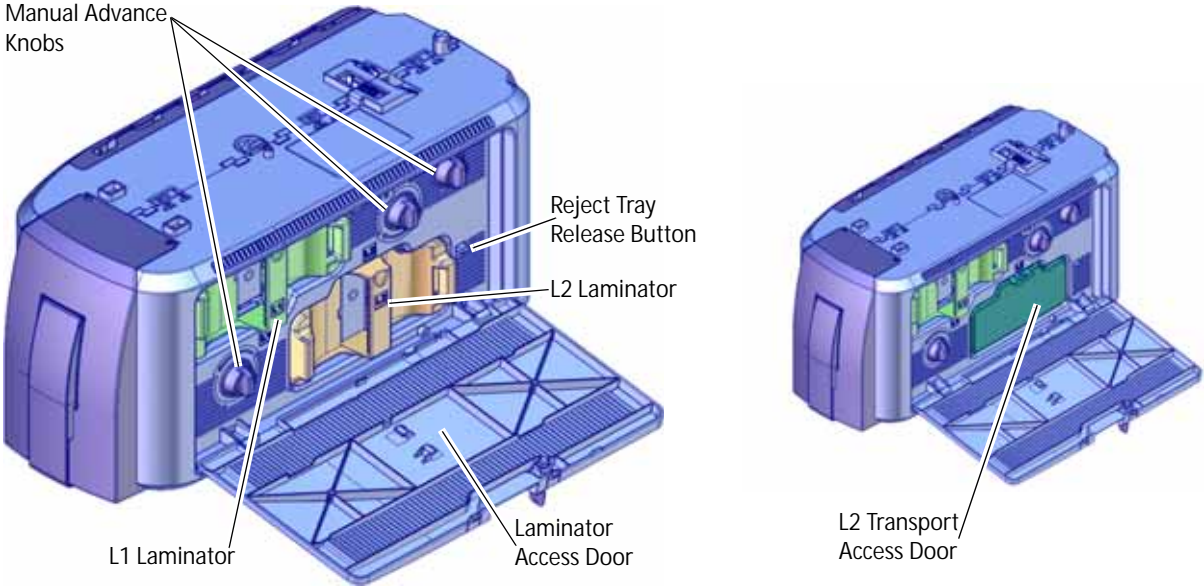

- Manual Advance Knobs**      The manual advance knobs move the card through the laminator to remove it from the system. Use the knobs to clear a card jam.
- L1 Laminator (green cartridge)**      The L1 laminator cartridge holds the overlay material and applies it to the card.
- L2 Laminator (orange cartridge)**      The L2 laminator cartridge holds overlay material and applies it to the card. The L2 laminator is optional.
- Reject Tray Release Button**      Press the release button to open the reject tray and remove incomplete cards. Available only on systems with locks.
- Laminator Access Door**      The access door provides access to the L1 and L2 laminators to load supplies or to clear a card jam.
- L2 Transport Access Door**      The L2 transport access door replaces the L2 laminator cartridge if the optional second laminator is not installed. Open the door to access the laminator card transport.

**i** If your system includes the optional second laminator (L2), make sure that the laminator cartridge is always installed even if the cartridge is not loaded with overlay material. If the cartridge is not in place, cards are not supported as they travel through the system and can fall into the bottom of the laminator.

# Laminator Configuration Label

The laminator configuration label is located inside the laminator on the laminator access door and beneath the L2 cartridge.

The configuration label shows the following information:

- Laminator name
- Serial number
- Configuration
- Part number
- Date and country of assembly.

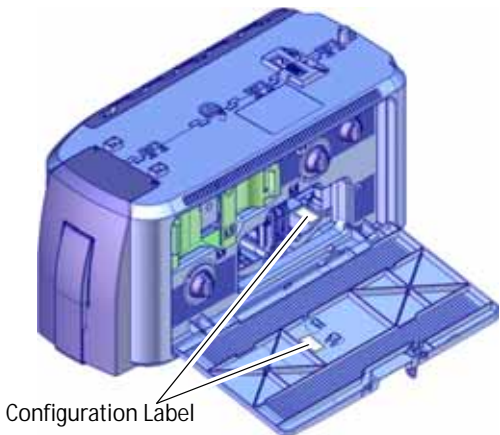

Additional labels may be attached to indicate options installed by the dealer or sales group after the laminator was manufactured.

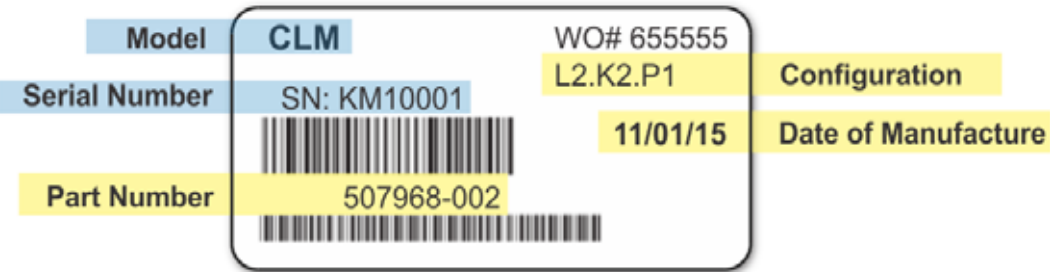

Option	Configuration Code
<b>Laminator</b>	L1=L1 Laminator L2=L1 and L2 Laminator
<b>Locks</b>	K1=Mechanical Locks K2=Electronic/Mechanical Locks blank=no lock option
<b>Other Options</b>	P1=Impresser

# Laminator Setup

The laminating system supports full-color print ribbons that do not have a topcoat (T) panel, including YMCK and YMCK-K ribbon. The topcoat or patch overlay applied by the laminators provides protection against wear and color fading, so the print ribbon topcoat panel is not needed. However, DuraShield clear and holographic overlays require that the ribbon topcoat be applied to the card first.

The system also supports full-color print ribbon with a front-side ultraviolet (UV) fluorescent panel, YMCKF-KT. The UV (F) panel is designed to create an optically variable image on the card. Refer to the printer's *Driver Guide* or the documentation for your card production application for information about designing a card to use a UV ribbon.

## Laminator Overlay Materials

The L1 and L2 laminators can apply either topcoat or patch material. Topcoat is a continuous film and patch is a die-cut polyester shape.

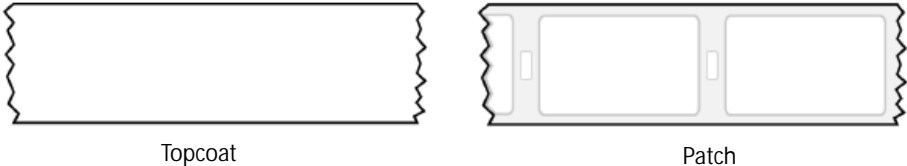

Patch overlays have a registration mark that is used by the printer to align the patch with the beginning of the card. The registration mark is a rectangular hole between the patches.

Patches can cover the entire card, can have an opening for a smart card chip, or can cover the card under the magnetic stripe. If both L1 and L2 laminators are installed, each laminator can apply different overlay material. For example, you might apply a patch that covers the complete card on the front, and a patch sized for a magnetic stripe on the back.

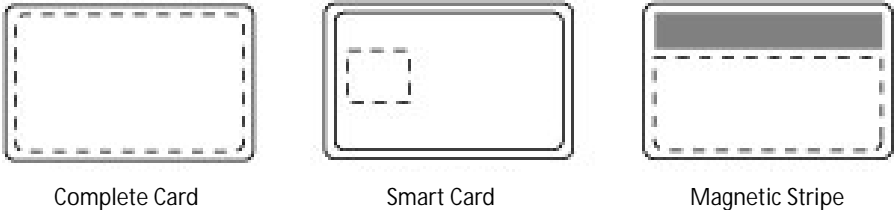

Both patch and topcoat overlays can be clear or can have a transparent holographic image on them. The holographic materials are called holographic topcoat or holographic patch and can be ordered with a custom image.

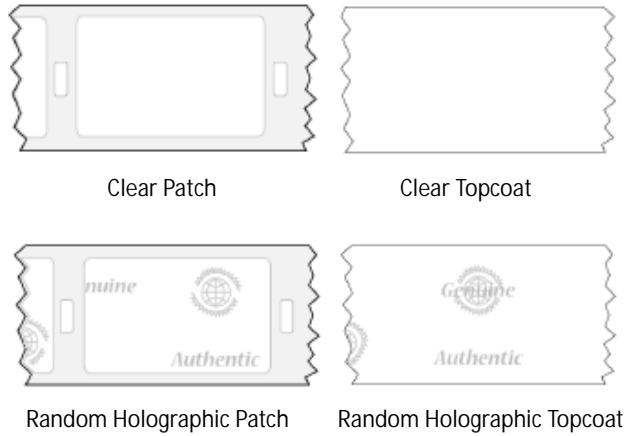

In addition, both holographic topcoat and holographic patch can be designed with a registered image that is located in the same position on each card. Registered holographic topcoat has a registration mark so that the image can be aligned with the card. Refer to the printer's *Installation and Administrator's Guide* for information about ordering overlay material.



If you use a custom holographic overlay, make sure that you know the location of important card features, such as photos and logos. Do not place holographic images where they interfere with the appearance of photos or machine-readable features.

# Load Laminator Overlay Material

Load the overlay material in one laminator cartridge at a time.

**i** The L1 (green) and L2 (orange) cartridges fit only in their assigned locations inside the laminator. They are not interchangeable.

- 1. Unlock and open the laminator access door.
- 2. Remove the L1 (green) laminator cartridge from the printer. Place the cartridge on a smooth level surface for loading.

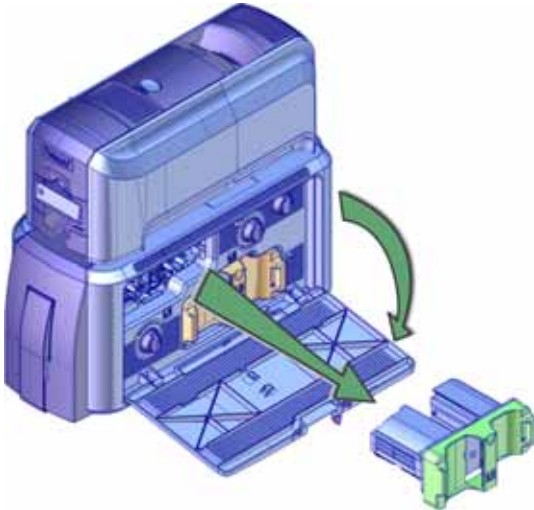

- 3. Push the release latch (a) and open the gate on the laminator cartridge (b).

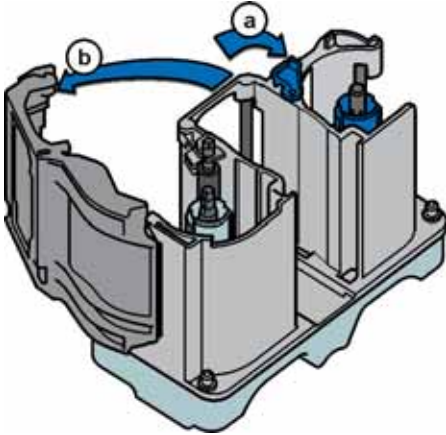

- 4. Remove both used spools from the cartridge (if present).

5. Load the new roll of laminator overlay material.
  - a. Put the blue supply spool on the blue supply spindle of the cartridge (c). The overlay supply roll can go on only one way and only fits on the correct spindle.
  - b. Put the empty silver take-up spool on the silver take-up spindle (d).
  - c. Turn the take-up spool clockwise to remove slack from the material (e). The overlay material loads in an S-shape.

Make sure that the overlay material is between the guides on both the take-up and supply sides of the cartridge.

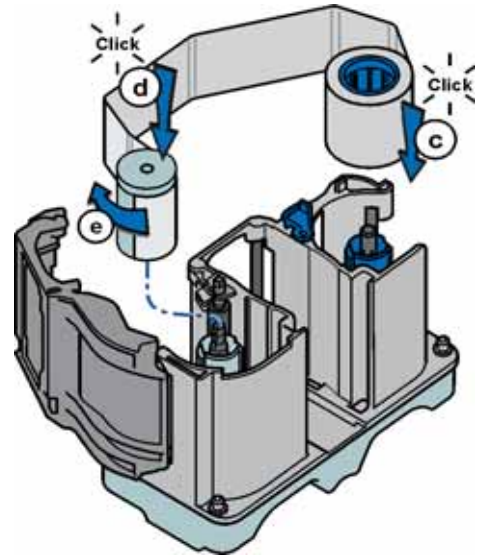

6. Close the laminator cartridge gate (f). Push it in until the latch clicks in place (g). Make sure that the overlay material is not pinched by the cartridge gate.
7. Replace the loaded laminator cartridge in the printer.
8. Remove the L2 (orange) cartridge, if installed, from the laminator.
9. Repeat steps 3 through 7 to load the overlay onto the L2 cartridge.
10. Close and lock the laminator access door.

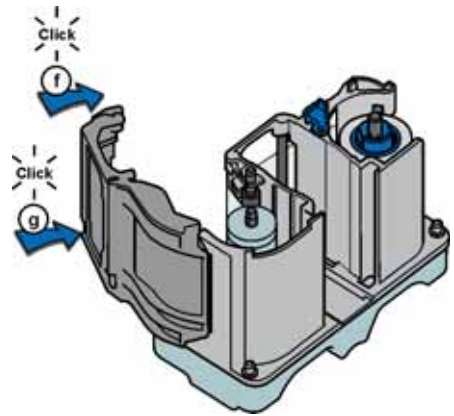



## Card Design

Set up your card design using your card production software or another application, such as Microsoft Word. You can specify your lamination preferences using the Card Printer Driver. Your card production software also may provide lamination settings.

The Card Printer Driver allows you to specify both printer and lamination preferences. Refer to your printer's *Driver Guide* for complete information about setting up printing preferences and lamination options.

- If the printer has one laminator, you can apply the overlay material to one or both sides of the card.
- If the printer has two laminators using different overlay materials, the quickest way to process a card is to apply the overlay in L1 to the front of the card and the overlay in L2 to the back of the card.

You can fine-tune the settings that control the application of the overlay using Printer Manager. Refer to the printer's *Installation and Administrator's Guide* for information about using Printer Manager.

## Verify Setup

After you set up the printer, print several test cards to determine how well the laminator applies material to the card. You can print test cards from the Card Printer Driver (refer to the printer's *Driver Guide*), from the printer LCD panel (refer to "[Print a Test Card](#)" on [page 20](#)), or from Printer Manager (refer to the printer's *Installation and Administrator's Guide*). You may need to print multiple test cards to make sure that the overlay is positioned correctly. The card stock, the card design, and the printer's environment all can affect the appearance of cards.

When evaluating a card, make sure that:

- The overlays are being applied properly:
  - Each overlay is applied completely to the card.
  - The material adheres well to the edges of the card.
  - The overlay does not come off when the card is bent or twisted.
- The card is debowed correctly.
- The impression is positioned correctly and has the proper depth.

If you need to make adjustments to the laminator or overlay settings, refer to the "Printer Manager" section of the printer's *Installation and Administrator's Guide*.

# Clear a Laminator Card Jam

1. Open the laminator access door.
2. Remove the L1 and L2 (if installed) laminator cartridges.

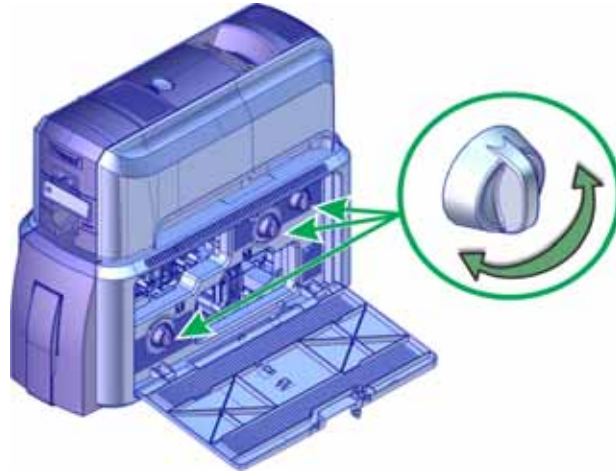

3. Turn the manual advance knobs inside of the laminator until the card is accessible.
4. Remove the card.
5. Replace the laminator cartridges.
6. Close the laminator access door.

# Clean the Laminator

Clean the laminator when at least one laminator cartridge is loaded with holographic overlay material and any of the following are true:

- Particles appear on the laminated cards.
- Particles are visible inside the laminator.

For examples of problems that require laminator cleaning, refer to [“Laminator Problems”](#) on page 59.



This procedure uses a double-sided, sticky cleaning card that removes holographic overlay particles from the laminator. When you clean the CD system using a regular cleaning card, the card also moves into the laminator and cleans the laminator rollers, the card entry area, and the impresser exit rollers. This is sufficient if you are not using holographic overlay. Refer to [“Run a Cleaning Card”](#) on page 36.

1. Unlock the laminator access door and remove the L1 and L2 laminator cartridges.

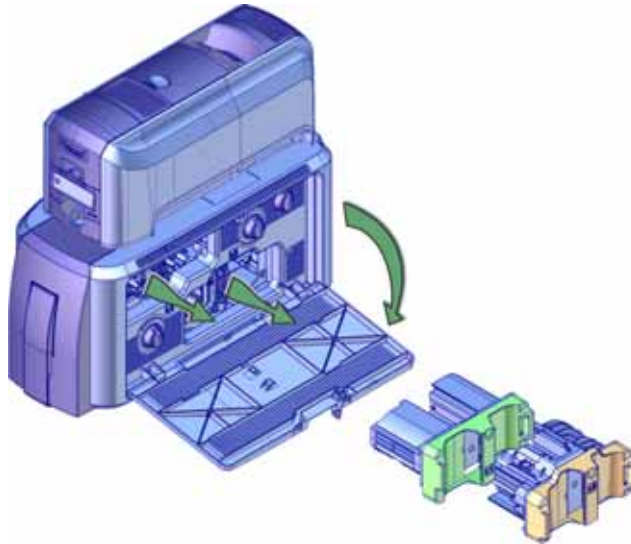

2. Remove printed cards from the output hopper, if necessary.

3. Remove the protective paper from both sides of the double-sided, sticky laminator cleaning card and insert the card under the rollers of the card exit slot of the laminator. When it is in the correct location and pushed in far enough, the card stays in place.

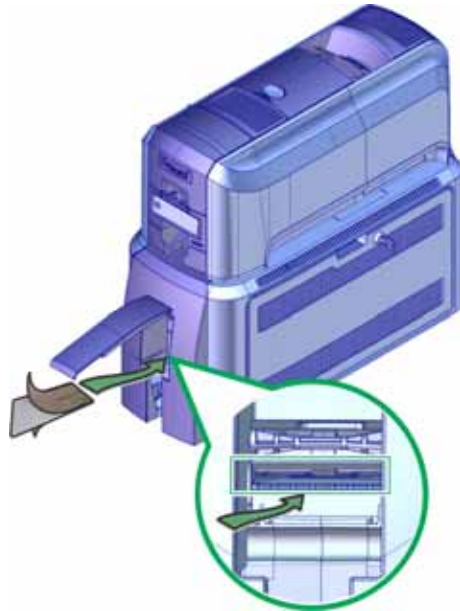

4. Use the LCD menu system to start the cleaning cycle.
  - a. Begin when the printer displays **Ready** and the USER button shows steady green. Press the USER button.

**Suspended** displays on line 1 of the LCD panel.

- b. Press ENTER to enter the menu system.
  - c. **Maintenance** displays on line 2 of the LCD panel. Press ENTER to enter the **Maintenance** menu.

- d. **Cleaning Card** displays on line 2 of the LCD panel. Press ENTER to enter the **Cleaning Card** menu.

- e. **Printer** displays on line 2 of the LCD panel. Press the down arrow.

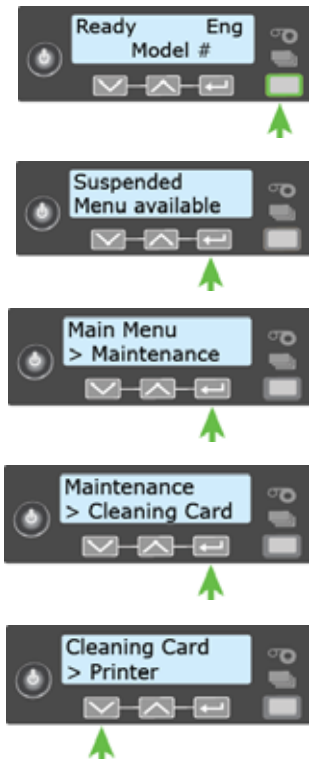

f. **Laminator** displays on line 2. Press ENTER.

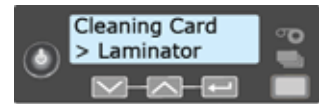

g. **Start** displays on line 2 of the LCD panel. Press ENTER to start the cleaning process.

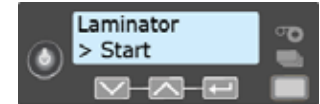

h. **Insert cleaning card** displays on the LCD panel. Press the USER button to start the cleaning cycle.

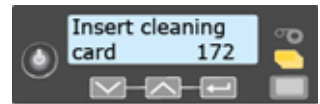

The laminator pulls the cleaning card from the card exit slot into the laminator and moves it back and forth through the L1 and L2 cartridge areas, the card entry area, and the exit rollers several times. If the system has locks, the used card is ejected into the laminator reject tray. If the system does not have locks, the used card is ejected into the laminator output hopper.

5. Inspect the laminator cartridges for particles. If particles are present:
  - a. Retrieve the laminator cleaning card and use it to remove the particles of overlay material from the cartridges.
  - b. If particles still remain on the cartridge and inside of the laminator, use a vacuum cleaner with a small plastic hose attachment to carefully remove the particles. Also clean any remaining particles from the output hopper.

#### HINTS & TIPS

- If the cleaning card is not pulled into the laminator, the card is not in the correct position. The cleaning card must be located under the rollers of the card exit slot inside the output hopper.
- At the end of the laminator cleaning cycle, the card can stick to the rollers in the output hopper. Pull on the card to remove it.
- Discard the laminator cleaning card after one use.
- Avoid contact with the heated roller, which contains sensitive electronic components.
- If cleaning the laminator does not solve the problem, contact your service provider for assistance.

