

USER GUIDE



MOCA ESPRESSO

Copyright

Matica Technologies
July 2016
All rights reserved

Copyright Notice

Users must respect the copyright regulations applicable in their own respective countries. Photocopying, translation, reproduction or transmission of this manual, in whole or in part, for any reason and using any electronic or mechanical means whatsoever, without the prior written permission of the Manufacturer company is strictly forbidden.

All contents of this manual are subject to change without prior notice.

The Manufacturer accepts no liability for any errors that may be found in this manual, or for any loss or damage that may arise accidentally or as a result of diffusion or use of this manual.

Trademarks

All other trademarks are the property of their respective owners.

Printer Warranty

Refer to the warranty statement provided with the printer for the warranty terms and conditions, and its limitations of liability.

Environmental Impact

Matica is committed to reducing the environmental impact of its products through improvements in energy efficiency.

DIRECTIVE 2002/96/EC ON THE TREATMENT, COLLECTION, RECYCLING AND DISPOSAL OF ELECTRIC AND ELECTRONIC DEVICES AND THEIR COMPONENTS

1. FOR COUNTRIES IN THE EUROPEAN UNION (EU)

The disposal of electric and electronic devices as solid urban waste is strictly prohibited: it must be collected separately. The dumping of these devices at unequipped and unauthorized places may have hazardous effects on health and the environment. Offenders will be subjected to the penalties and measures laid down by the law.

TO DISPOSE OF OUR DEVICES CORRECTLY:

- a) Contact the Local Authorities, who will give you the practical information you need and the instructions for handling the waste correctly, for example: location and times of the waste collection centres, etc.
- b) When you purchase a new device of ours, give a used device similar to the one purchased to our dealer for disposal.



The crossed dustbin symbol on the device means that:

- When it to be disposed of, the device is to be taken to the equipped waste collection centres and is to be handled separately from urban waste;

- *Matica Technologies* guarantees the activation of the treatment, collection, recycling and disposal procedures in accordance with Directive 2002/96/EC (and subsequent amendments).

2. FOR OTHER COUNTRIES (NOT IN THE EU)

The treatment, collection, recycling and disposal of electric and electronic devices will be carried out in accordance with the laws in force in the country in question.

For Europe*Warning*

“This is a Class A product. In a domestic environment this product may cause radio interference in which case the user may be required to take adequate measures.”

For US

“This equipment has been tested and found to comply with the limits for a Class A digital device, pursuant to part 15 of the FCC Rules. These limits are designed to provide reasonable protection against harmful interference when the equipment is operated in a commercial environment. This equipment generates, uses, and can radiate radio frequency energy and, if not installed and used in accordance with the instruction manual, may cause harmful interference to radio communications. Operation of this equipment in a residential area is likely to cause harmful interference in which case the user will be required to correct the interference at his own expense”.

Safe for human operation at <20cm usage conditions as SAR exempt under Title 47 CFR Part §2.1093 due to low power transmission.

For Canada

This device complies with Industry Canada’s licence-exempt RSSs. Operation is subject to the following two conditions:

- (1) This device may not cause interference; and*
- (2) This device must accept any interference, including interference that may cause undesired operation of the device.*

Safe for human operation at <20cm usage conditions as SAR exempt under RSS-102 Section 2.5.1 due to low power transmission.

Table of Contents

PRODUCT OVERVIEW	1-1
GETTING STARTED	1-1
Unpacking the Printer	1-2
Functional Description	1-3
<i>Front View</i>	1-3
<i>Operator Panel</i>	1-3
<i>Rear View</i>	1-4
<i>Power Supply</i>	1-4
<i>Plastic Cards</i>	1-4
INSTALLATION PROCEDURES	2-1
Installing the Ribbon	2-1
Card Feeding	2-2
<i>Input Hopper (Automatic Card Feeder)</i>	2-2
Adjusting the Card Thickness	2-3
Connecting the Power Supply and Powering ON the Printer	2-4
INSTALLING THE SOFTWARE AND CONFIGURING THE PRINTER	3-1
Connecting the Printer to the Computer and Installing the Software	3-1
USB connection	3-2
Ethernet (LAN) connection via DHCP	3-3
Ethernet (LAN) connection with fixed IP	3-6
Uninstall Program Tabs	3-8
Add a second printer or change the type of connection	3-8
Matica Printer Manager	3-9
<i>Using the Printer Manager Instrument Bar</i>	3-9
Printers Management	3-9
Printer Manager	3-10
<i>Status</i>	3-10
<i>Preferences</i>	3-11
<i>Maintenance</i>	3-12
<i>Encoding (optional)</i>	3-12
<i>Settings</i>	3-13
<i>Updating the Printer Firmware</i>	3-14
<i>Duplex activation</i>	3-14
<i>Options</i>	3-14
Printer Status Pop-up	3-14
PRINTING	4-1
Card Printing	4-1
<i>Card Printing Using Word</i>	4-1
<i>Management of the Overlay panel</i>	4-2
Double-side Printing	4-3
Color Settings	4-4

PRINTER MAINTENANCE	5-1
Printer Routine Cleaning	5-1
Standard Cleaning	5-1
<i>Standard Cleaning Procedure.....</i>	<i>5-1</i>
Card Path Advanced Cleaning.....	5-3
<i>Advanced Cleaning Procedure</i>	<i>5-3</i>
Cleaning Roller Advanced Cleaning	5-5
<i>Roller Cleaning Procedure.....</i>	<i>5-5</i>
Printhead Cleaning.....	5-7
<i>Printhead Cleaning Procedure.....</i>	<i>5-7</i>
Printing Test Cards	5-8
<i>Printing a Text Test Card.....</i>	<i>5-8</i>
<i>Printing Graphic Test Card</i>	<i>5-8</i>
<i>Printing a Dual-Side Test Card</i>	<i>5-8</i>
Print head replacement procedure	5-9
<i>Replacement procedure</i>	<i>5-9</i>
ENCODING OPTIONS	6-1
Chip Encoding	6-1
<i>Encoding Test.....</i>	<i>6-1</i>
<i>Test</i>	<i>6-2</i>
<i>Reading the Chip Encoding.....</i>	<i>6-2</i>
External Encoding	6-3
Magnetic Encoding	6-3
<i>Configuration</i>	<i>6-4</i>
<i>Test and Encoding.....</i>	<i>6-5</i>
TROUBLESHOOTING	7-1
Printer does not power on	7-1
Printer has printing problems.....	7-1
Printer has problem with ribbon	7-2
Chip Encoding problems	7-2
Software problems.....	7-2
RIBBONS	8-1
CLEANING KITS.....	8-1
TECHNICAL CHARACTERISTICS.....	9-1

Product Overview

The printer described in this User Guide provides full color dye-sublimation or monochrome thermal transfer printing on standard 54x86 mm plastic cards. PVC, PVC Composite, PET, ABS and PET cards are supported (accordingly with varnished card product configuration). It is managed from the computer through the USB port or via Ethernet/WiFi.

The ribbon carrier, that comes with the printer, allows the ribbon to be replaced quickly and easily.

A number of options are available so that the printer can be configured to operate in different types of environments:

- Magnetic encoder
- Smart Card Encoding Station
- Contact and Contactless Smart Card encoder
- 10/100 Ethernet and/or 802-11 Wi-Fi connection
- Single Card Feed Option
- Connection for external smart card encoding.

Getting Started

The printer comes with a number of accessories; check carefully that they have been all received. The list of accessories may vary according to printer model.

The printer is shipped in special packaging designed to prevent damage during transportation. If any visible damage is noticed upon reception, contact the dealer immediately.

Maintain the printer packaging intact and store it in a clean and dry place.

Note: If the printer has to be returned, it must be returned integrally with its full original packaging (box, inner wedges and protective bags). If it is returned without its original packaging and any components are damaged during transportation, such components will no longer be covered by the warranty. Matica will also charge for the new packaging which will be required to ship the printer back.

Unpacking the Printer

The following items are included in the box:

- Printer
- Software CD-ROM containing the installer, printer driver and Printer Manager
- The Placemat
- Warranty and Customer Service Information
- Cleaning kit
- Power cord
- Power supply
- USB cable
- USB cable
- Reject bin, optional for Moca **(1)**

Note: Contact the dealer immediately if any of the items listed above is missing.
Only use the power supply provided with the printer.

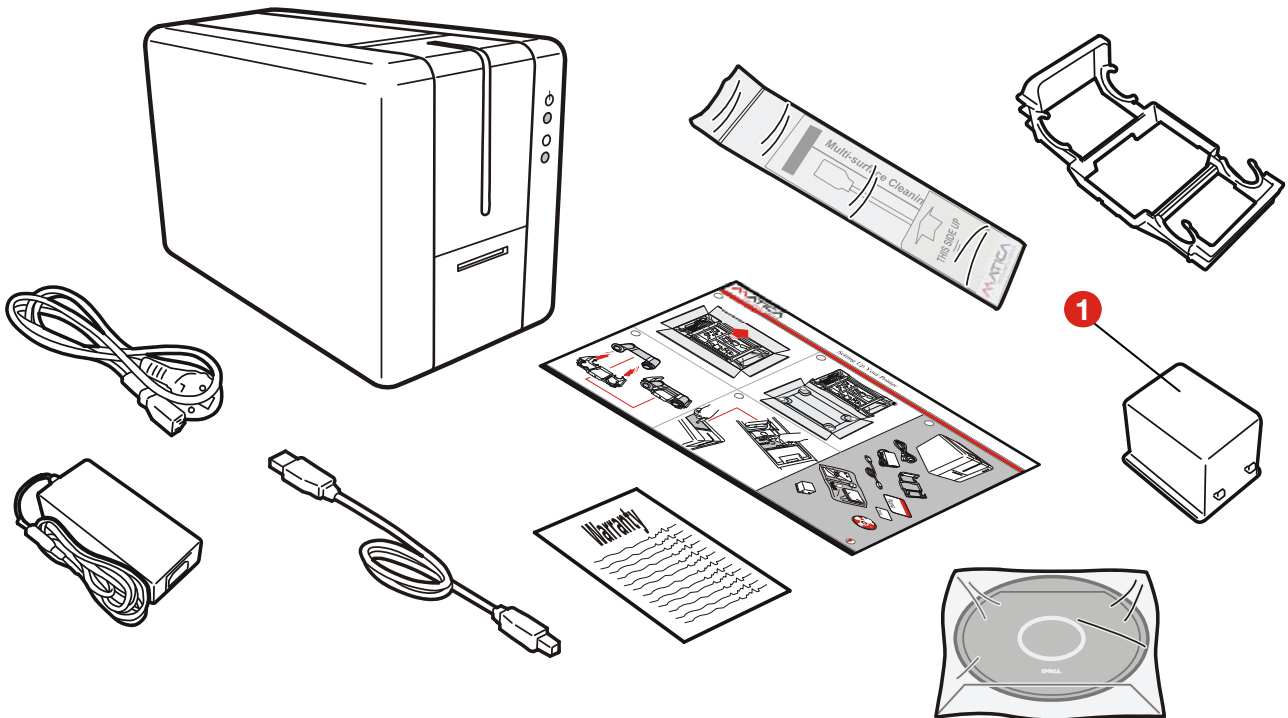

Functional Description

Front View

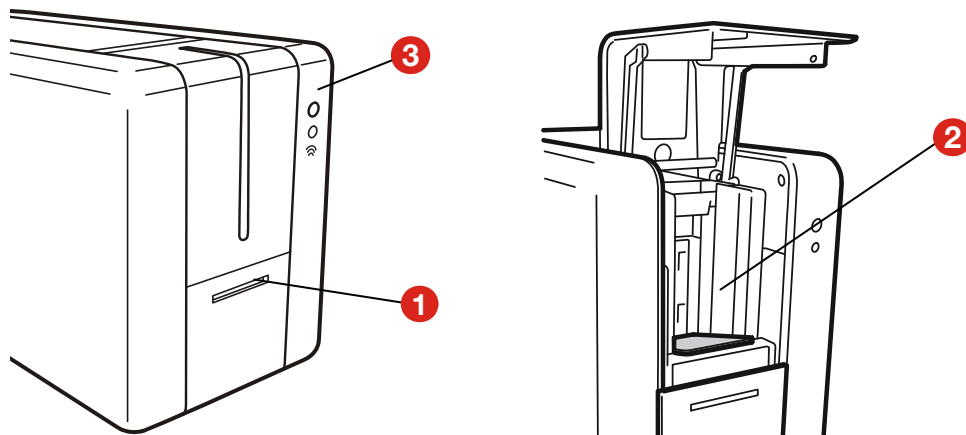

The front of the printer is the operator side and features:

- 1) Front slot (only when this option has been ordered)
- 2) Input Hopper
- 3) Operator panel and printer status indicators.

Operator Panel

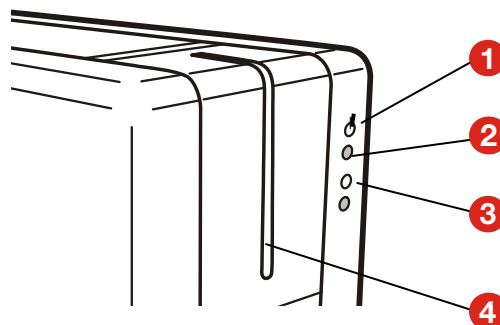

The front operator panel consists of:

- 1) Icon that indicate the ON switch
- 2) ON/OFF toggle switch
- 3) 3-color LED (amber, red and green) indicating the printer's functional status or an error condition.
 - **Green**
On steady → Printer ready
Flashing → Printer receiving data or printing
 - **Amber**
On Steady → Ribbon almost finished
Flashing → Operational error: no ribbon or card detected
 - **Red**
On Steady → Mechanical error (cover open, incorrect card insertion or faulty mechanical component)
Flashing → Servicing required (during cleaning, heating, cooling or during firmware upgrade)
- 4) Backlit blue stripe: illuminates the Card Hopper to simplify card detection.

Rear View

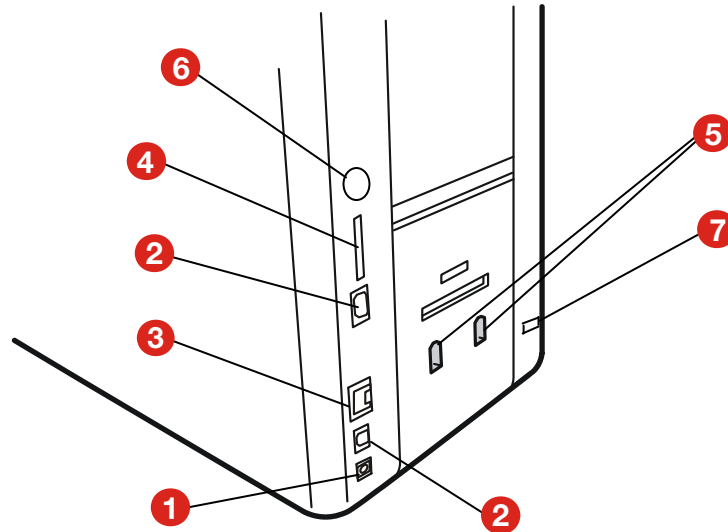

The following components are located on the back panel:

- 1) Power cord socket
- 2) Two USB connectors (Type A and B)
- 3) Ethernet connector with traffic LED (option)
- 4) SD card (option) slot
- 5) Reject bin attachment slots
- 6) External smart encoder (option) connector
- 7) Kensington lock.

Power Supply

The printer comes with an external auto-switching power supply.

Note: Only use the power supply provided with the printer.

Plastic Cards

Listed below are the plastic card specifications:

- **Type:** Composite PVC, PET, ABS (varnished)
- **Dimensions:** ISO CR80 - ISO 7810 (53.98 x 85.60)
- **Thickness:** 0.25 to 1.25 mm (10 to 50 mil) manual gauge adjustment
- **Magnetic stripe:** ISO 7811
- **Smart Card Contact:** ISO 7816-1,2,3,4
- **Smart Card Contactless:** ISO 14443A/B.

Installation Procedures

Installing the Ribbon

Original Matica ribbons are to be installed carefully. The ribbon carrier that comes with the printer helps to install the ribbon quickly, easily and accurately. Once the ribbon is in its carrier, the carrier can then be easily dropped into the printer using the yellow guides.

1) Installing the ribbon

2) Insert the ribbon (not provided with the printer) into the ribbon carrier.

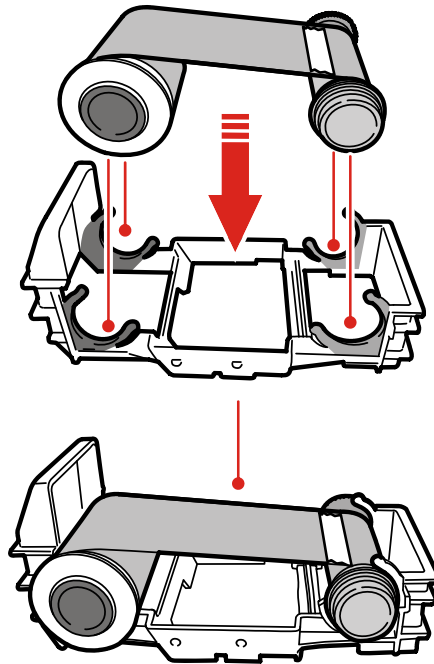

3) Open the printing module compartment cover.

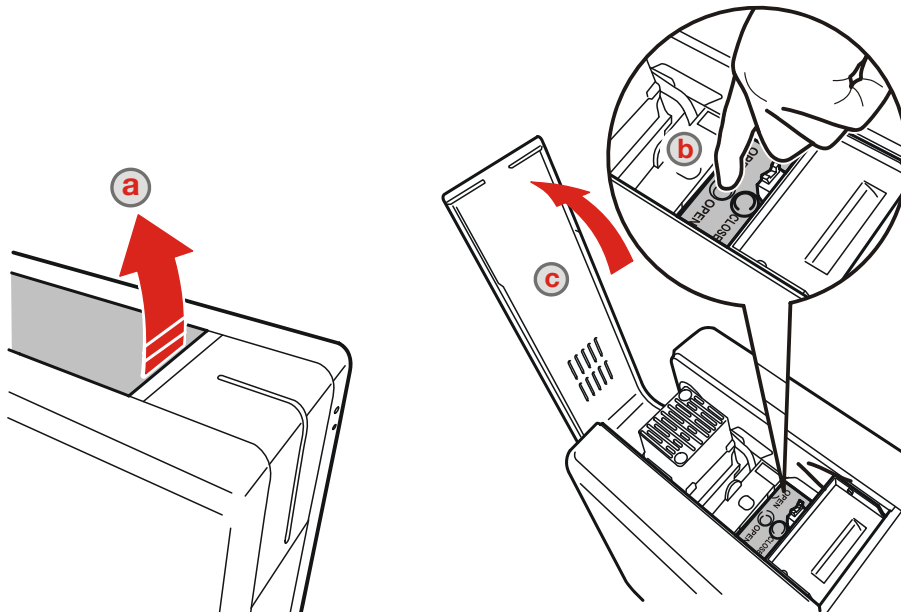

4) Insert the ribbon carrier into the printer, looking for the yellow guides that have the same color as the take-up core.

5) Close the printing module compartment cover.

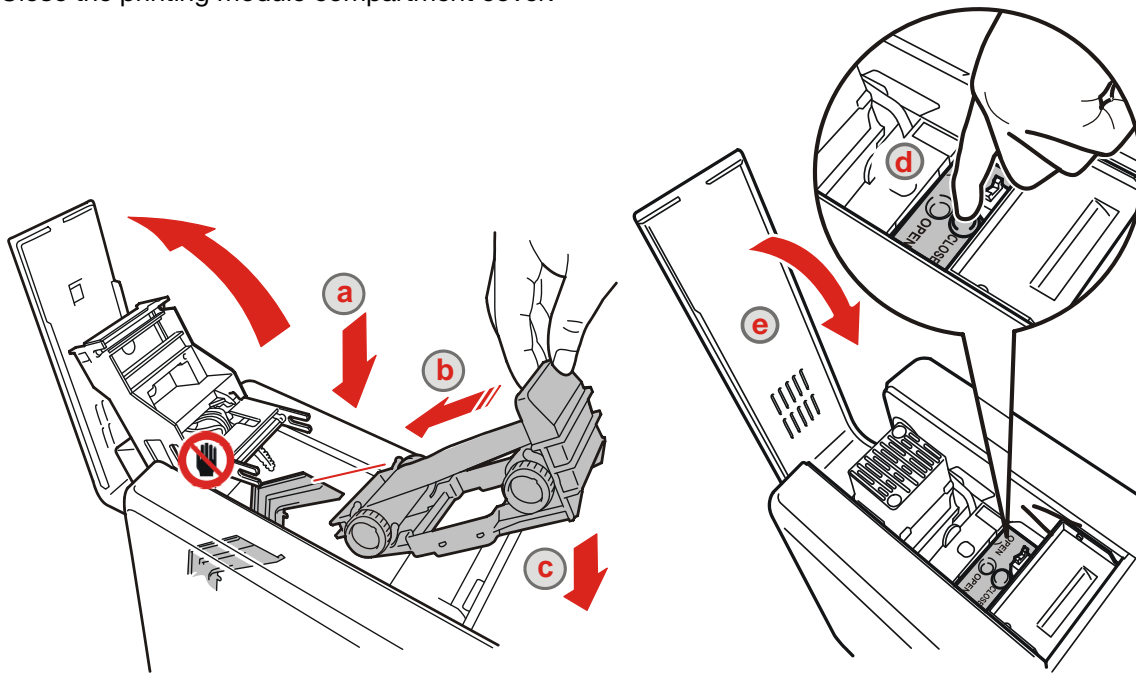

Note: Keep away from the printhead so as avoid damaging it.

Card Feeding

The input Hopper (automatic card feeder) can hold a maximum of one hundred 0.76 mm thick cards. A label inside the door gives the instructions for correctly positioning and orienting the card.

When the single card manual feeder option is present, it can be used without needing to empty the input Hopper.

The card path can be selected via software to speed card processing:

- *Hopper*
- *Reject bin.*

The output tray in the front part of the printer has a capacity of eighty or thirty cards with a thickness of 0.76 mm, according to whether the manual feed option is present for the Moca model.

Input Hopper (Automatic Card Feeder)

1) Open the Hopper door on the operator panel by pressing at point (a) indicated in the figure below. Load the cards in the Hopper (b) and then close the door.

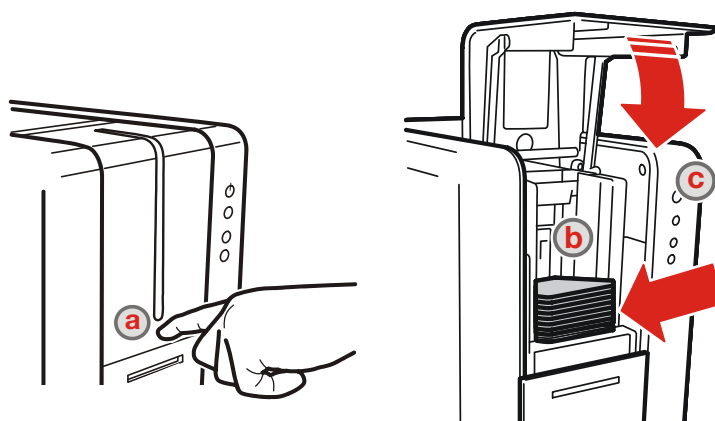

Adjusting the Card Thickness

The card thickness can be adjusted using the wheel inside the input Hopper.

Cards with thicknesses ranging between 0.25 mm and 1.25 mm (10 - 50 mil) can be processed by the printer. Proceed as follows to adjust the card thickness:

- 1) Open the printing module compartment cover.
- 2) Rotate the green wheel until the arrow points to the thickness of the card to be printed.

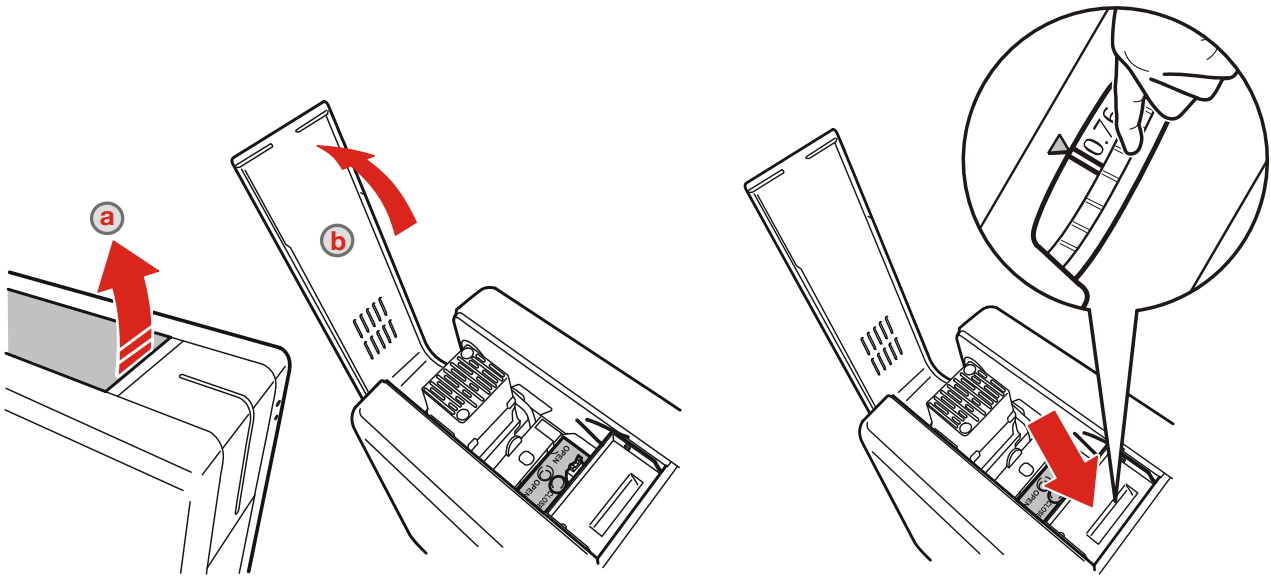

- 3) Close the printing module compartment cover.

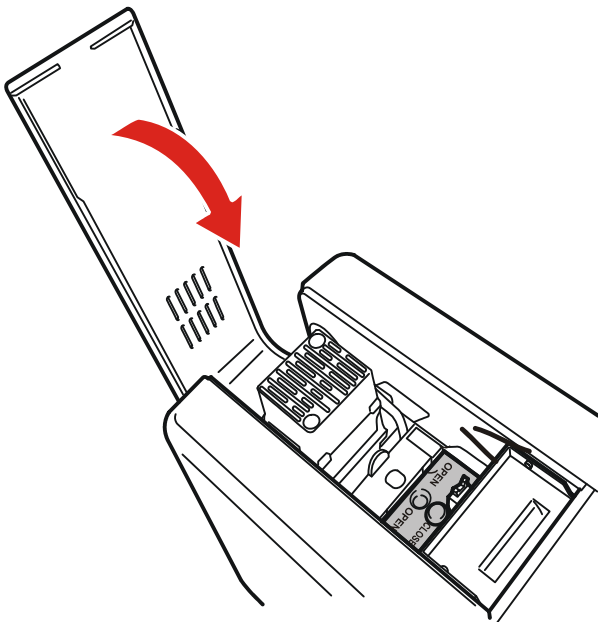

Connecting the Power Supply and Powering ON the Printer

Connect the power cord to the power outlet, to the power supply and then connect the power supply to the printer as shown below. Press the ON/OFF button to power on the printer.

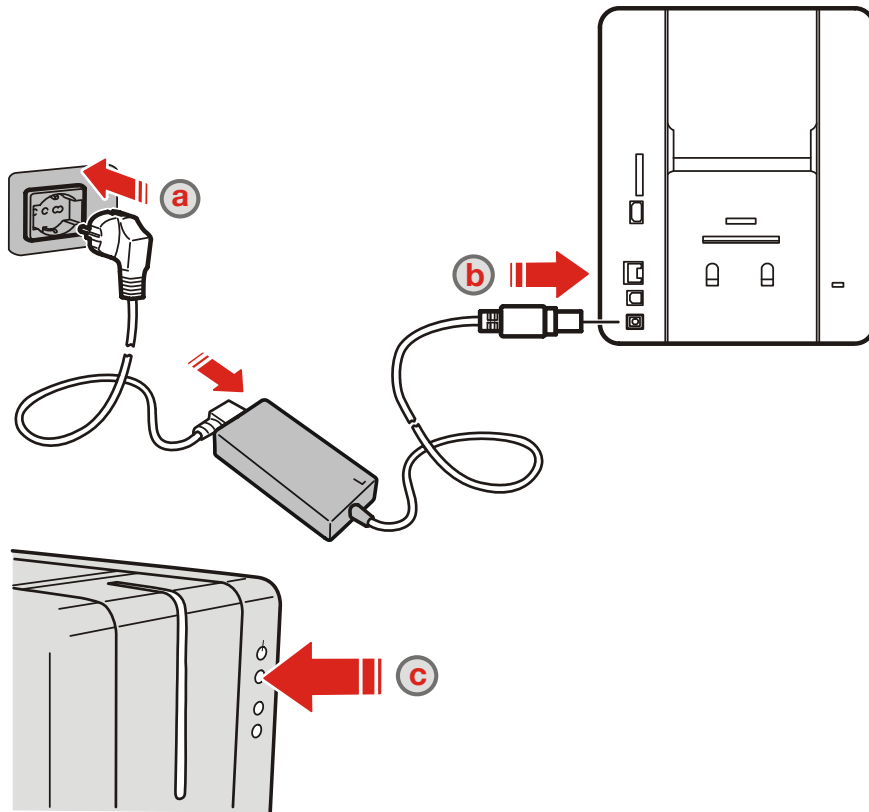

Installing the Software and Configuring the Printer

The CD-ROM that comes with the printer contains the following:

- Windows Vista, Seven, Win 8.1, Win 10 (supported 32 and 64 bit) printer driver for USB, Ethernet LAN and Wireless connections (if supported by the purchased model)
- Printer Manager application
- PDF User Guide
- Setting up your Printer in PDF format.

Connecting the Printer to the Computer and Installing the Software

1) Power on the computer and then insert the CD-ROM into the drive. Follow the instructions displayed by the setup program.

Note: Do not connect the printer yet; the setup program will instruct when to do so.

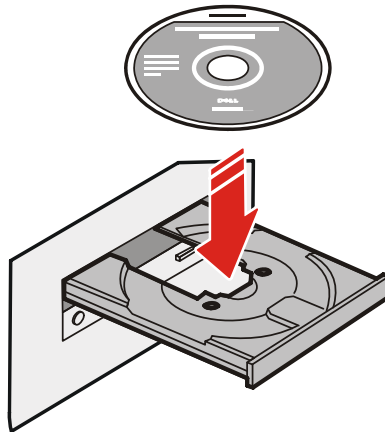

2) The setup program residing on the CD-ROM executes automatically and the following screen is displayed:

Note: if the configuration program is not run automatically, proceed in manual mode as indicated below:

- Select system resources> CD-ROM/DVD
- Double click on the installation program. The following language selection page is displayed.
- Confirm with **OK**. The display shows:

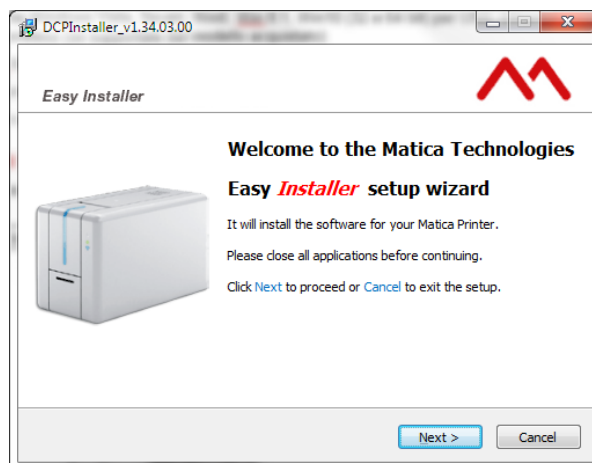

- 3) Click **Next** and then “I accept the agreement” to accept the licence agreement. Then, click **Next**. The display shows:

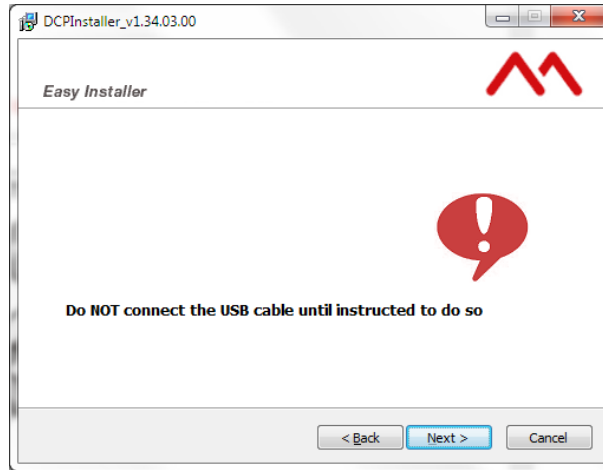

- 4) Click **Next**. The installation program will ask you to indicate the folder in which to save the files (the disk space necessary for installation is indicated at the bottom of the screen page).
- 5) Click **Next**. A prompt is displayed regarding program user privileges. Choose between **For all the users** and **only for current user**; then click **Next** to continue. A summary screen page with the settings selected is displayed.
- 6) Click **Install**. On completion of the installation procedure, the following screen page is displayed:

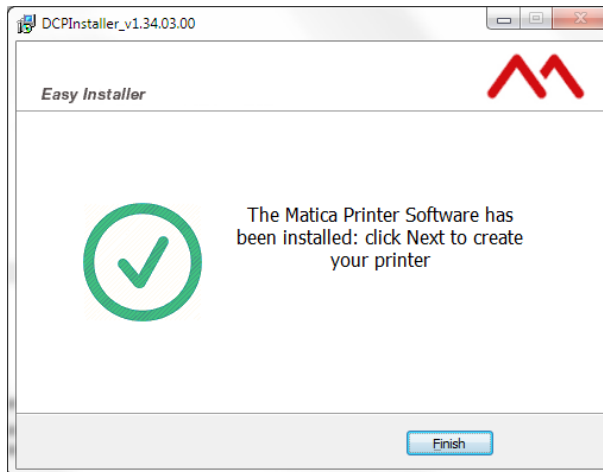

Note: a Windows message may be displayed asking whether the installation driver is to be considered reliable. In this case, confirm, selecting **Install**.

- 7) Click **Finish** to terminate installation.

The system requests restart of Windows to complete installation.

USB connection

On completion of installation, the system is ready to use the printer with USB connection.

Switch on the printer and connect this to the computer using the USB cable.

Ethernet (LAN) connection via DHCP

The **Add Printer Wizard** program permits selection of printer connection mode. The options are: Ethernet/LAN or Wireless (WiFi).

Note: To run the **Add Printer Wizard** program manually, activate this from the **Start > Programs > Matica** menu.

Note: The configuration of the connection can be modified at any time activating Wizard mode from the **Add Printer Wizard** program.

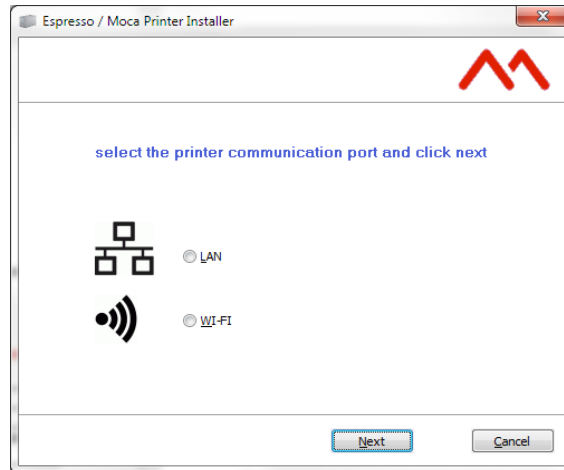

Click the **LAN** button in the screen page of the **Add Printer Wizard** program.

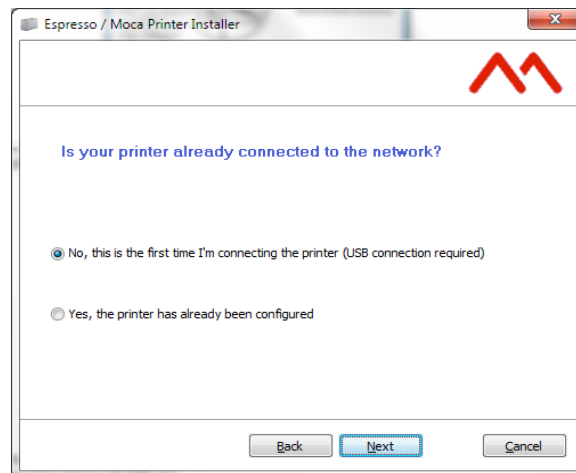

For first-time configuration of the printer select, **No, this is the first time...** and then **Next**.

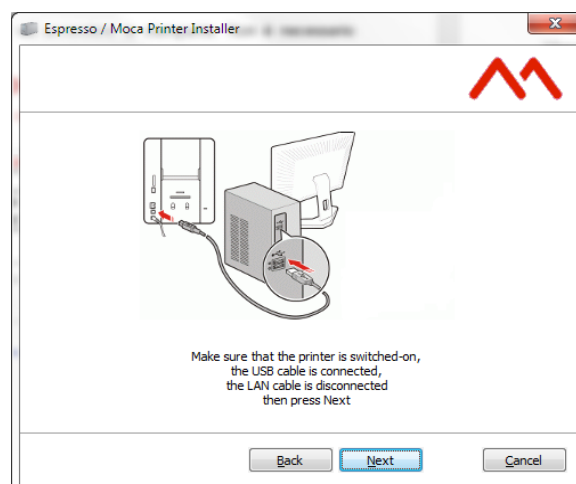

Check that the printer is ON and connected with the USB cable. Do not connect the network cable to the printer, then click **Next**. The configuration software displays the following screen page:

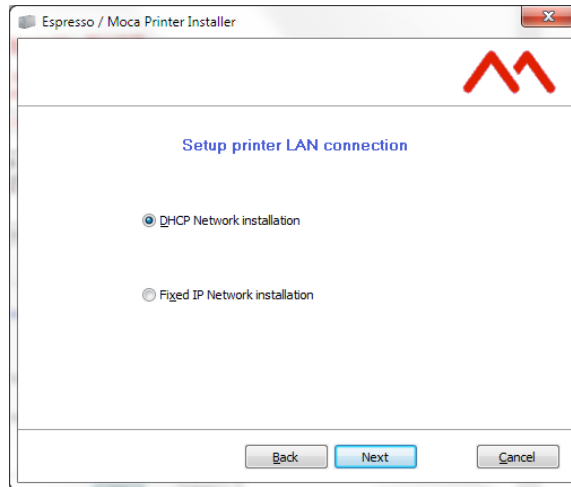

Select **DHCP Network installation** network mode and click **Next**

Note: for further information about the specific company network, contact the network administrator. Automatic selection of DHCP Network Installation is advisable for the most common types of installation.

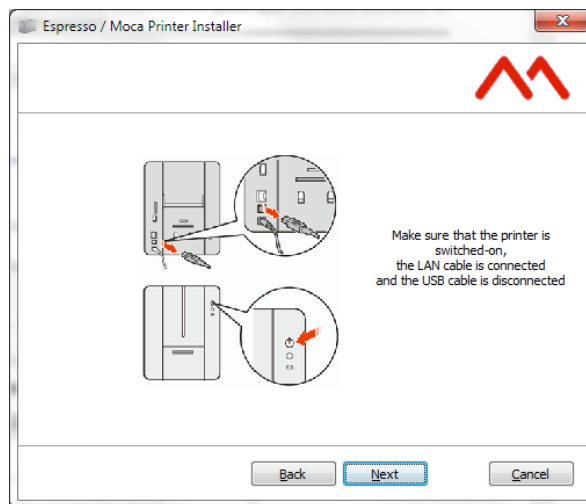

Check that the printer is ON, disconnect the USB cable and connect the network cable. Click **Next** to continue.

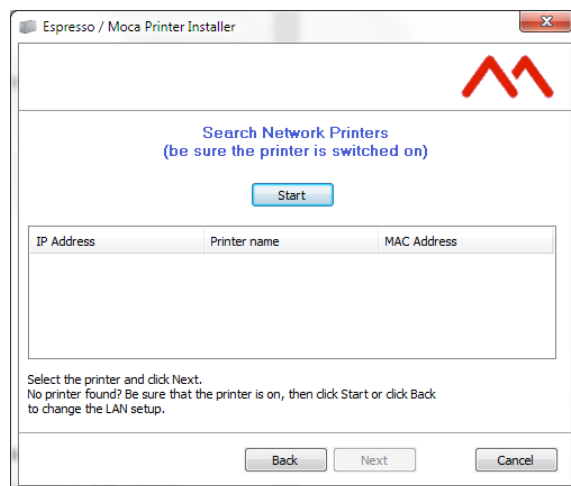

Click **Start** to search for the network printer and wait until this has been identified.

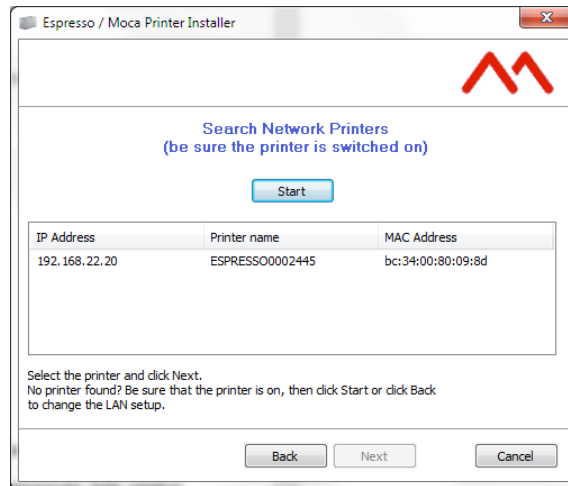

If the printer is not found, click **Start** to repeat the search for the network printer and wait until this has been identified.

Once it has been found, the printer is shown in the list of available printers accompanied by the related information (IP address name of the printer, Mac address).

Click **Next** and wait until the configuration software recognises the printer.

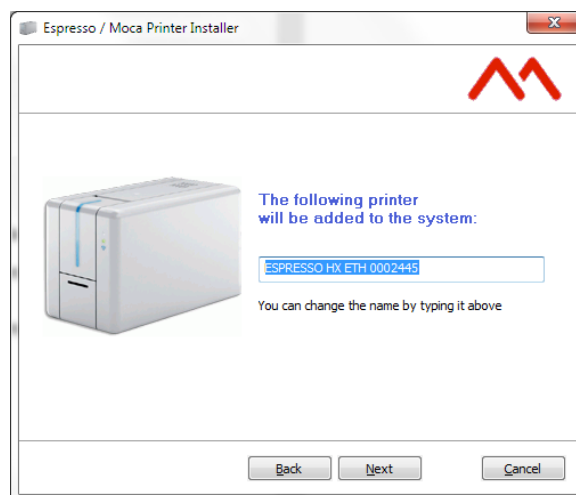

Click **Next** and wait until the configuration software displays the message indicating that installation has been completed successfully.

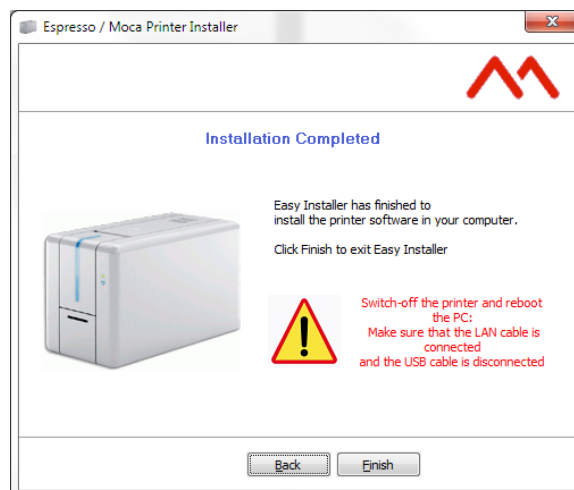

Terminate installation clicking **Finish** and follow the instructions shown on the display.

Ethernet (LAN) connection with fixed IP

The **Add Printer Wizard** program permits selection of printer connection mode. The options are: Ethernet/LAN or Wireless (WiFi).

Note: To run the **Add Printer Wizard** program manually, activate this from the **Start > Programs > Matica** menu.

Note: The configuration of the connection can be modified at any time activating Wizard mode from the Add Printer Wizard program.

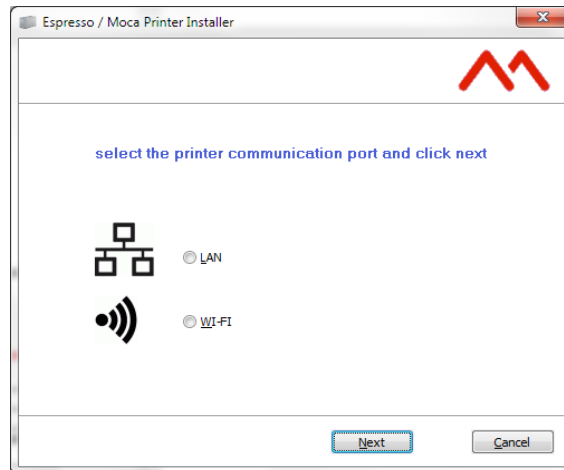

Click the **LAN** button in the screen page of the **Add Printer Wizard** program.

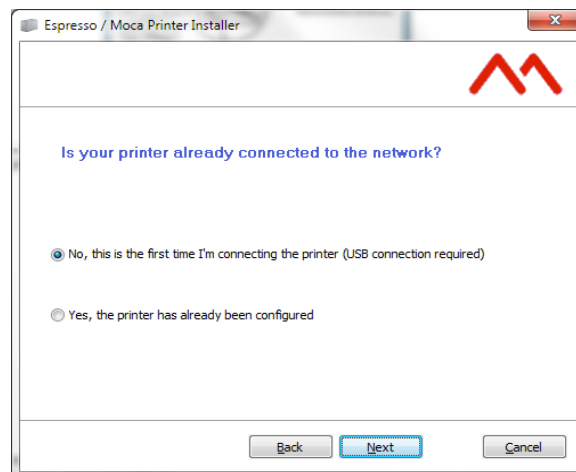

For first-time configuration of the printer select, **No, this is the first time...** and then **Next**.

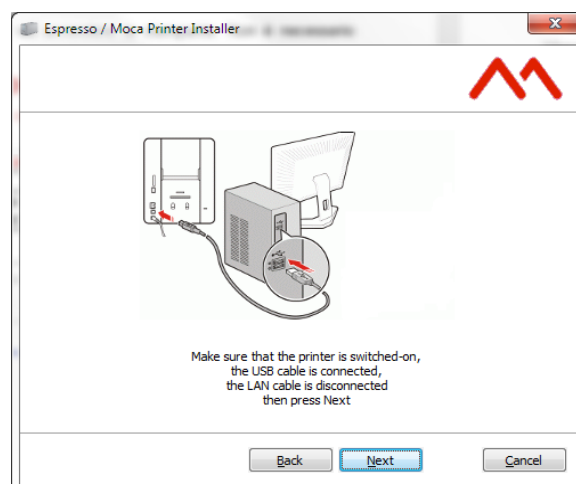

Check that the printer is ON and connected with the USB cable.
Do not connect the network cable to the printer, then click **Next**.
The configuration software displays the following screen page:

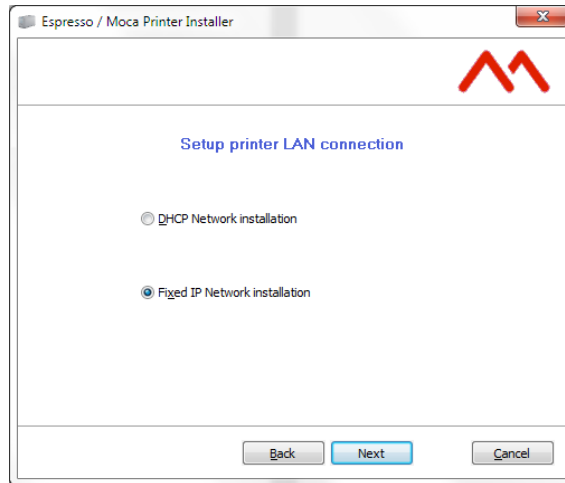

Select **Fixed IP Network installation** network mode and Click **Next**

Note: for further information about the specific company network, contact the network administrator. Automatic selection of DHCP Network Installation is advisable for the most common types of installation.

A screen page is displayed for manual entry of network parameters (in the case of part of a company network, it may be necessary to contact the network administrator for further information).

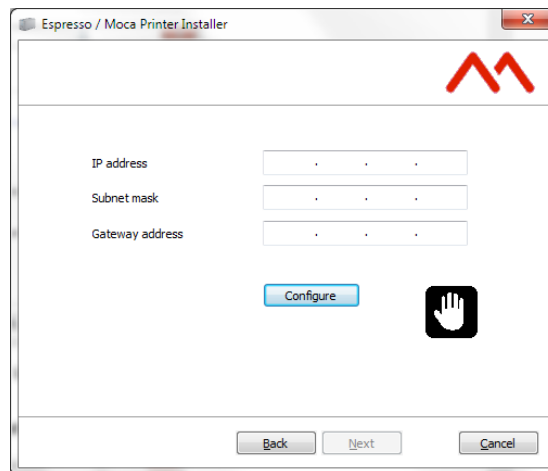

Click **Configure**, wait for insertion of network data and click **Next**.

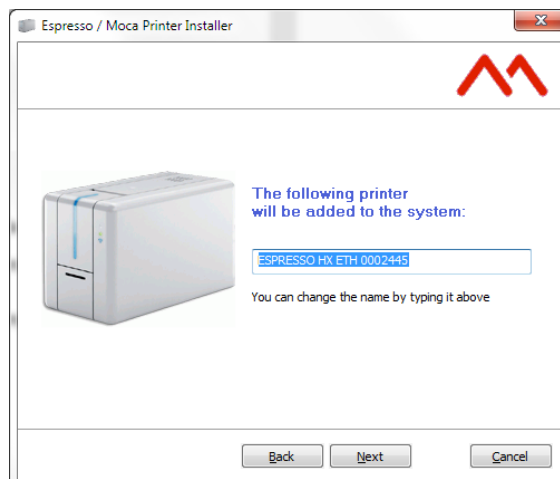

Click **Next** and wait until the configuration software displays the message indicating that installation has been completed successfully.

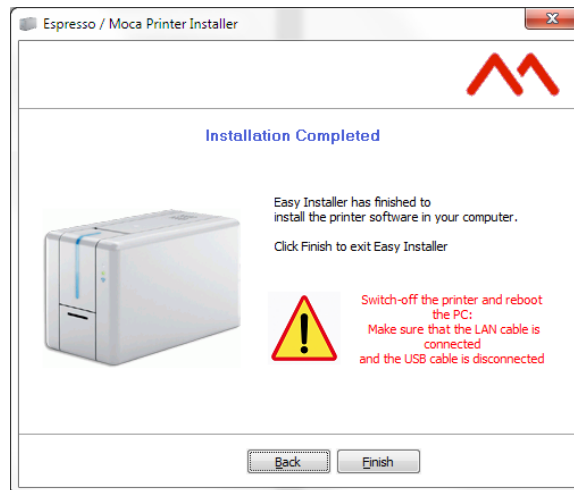

Terminate clicking **Finish** and follow the instructions shown on the display.

Uninstall Program Tabs

To uninstall the software:

1) in Windows 7, Windows 8.1/10, select Programs and Features > Matica Espresso Driver/manager v.1.34.xxx..

Note: Alternatively, remove manually the DCP Matica applications.

1) in Windows 7, Windows 8.1/10, run the program
C:\Program Files (x86)\Matica\Espresso\unins000.exe.

Add a second printer or change the type of connection

On terminating the installation, the program *Add Printer Wizard* appears in the Windows Start menu > All Programs > *Matica* > *DCP*.

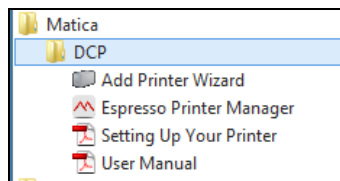

Using this program you can run the program Add Printer Wizard Program communication at any time to add or modify a printer connection of type USB, LAN or WiFi.

This allows you to choose the type of connection you want to use without having to repeat the installation from the start, maintaining also a number of printers connected to different communication ports (USB, LAN, WiFi) in the Windows spooler.

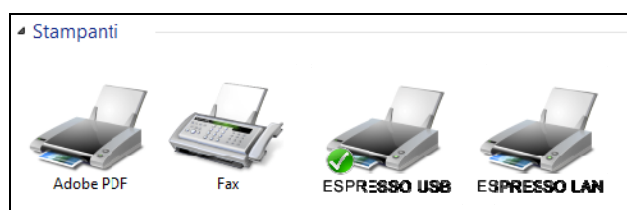

Matica Printer Manager

Upon successful installation, the following programs are installed on the computer:

- *Add Printer Wizard*
- *Espresso Printer Manager software to manage the printer*
- *Setting Up Your Printe in PDF formatr*
- *User Manual in PDF format.*

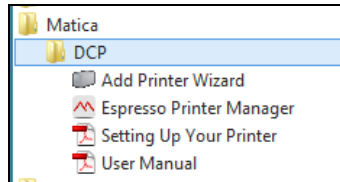

Using the Printer Manager Instrument Bar

The Windows toolbar includes the Matica application logo that, when clicked, displays a popup window from where the Printer Status can be launched. Left-clicking the related icon on the instrument bar opens the Printer Manager program.

Right-clicking the related icon on the instrument bar opens the Windows menu popup program.

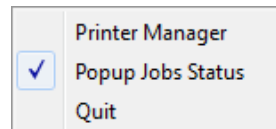

The menu consists of the following:

- **Printer Manager:** Opens the Printer Manager program
- **Popup Job Status**
- **Quit:** closes the program.

Printers Management

The Printers Management window is displayed, as shown below, when the program is executed from the Application bar or from Windows programs.

All the printer drivers installed on the computer are displayed in this window. From here, the Printer Manager can be launched for a given printer by double-clicking on the related printer name.

The following information is available in this window:

- 1) Printer Name:** the name of the printer is displayed in this area. The printer name can be defined by the user during the installation; if is not defined by the user, it will be defined from the program during the installation in which case it will be composed of the printer name and the port where it was connected during installation.

Double clicking the printer name opens the Printer Manager.

- 2) Connection:** the following connectivity is supported:

- USB (Local Connection)
- WiFi Access Point (Printer Internal Router)
- LAN (cable)
- WLAN (WiFi).

- 3) Printer Status:** this area can provide the following information:

- a) Ready – Standby
- b) Off-line
- c) Job underway – Error (with a brief description of the error)

Printer Manager

Open the **Print Manager** by double-clicking in the Application bar icon .

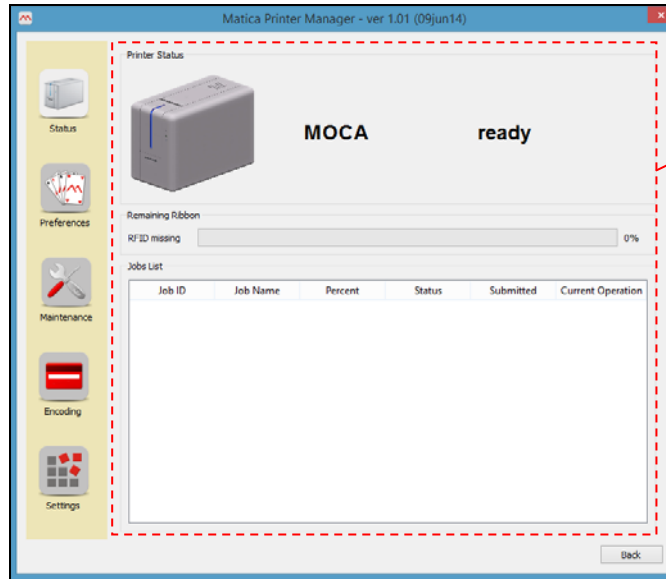

1) Information regarding the printer installed, or on its configuration, is displayed in this area. These contents are associated to the icon button displayed on the left hand-side of the window.

The following Printer Manager function icon buttons are provided:

- **Status**
- **Preferences**
- **Maintenance**
- **Encoding (only for the models supporting this feature)**
- **Settings**
- **Help.**

Click **Back** to return to the printer management window.

Note: The Encoding icon will be displayed only when the Encoding option is available.

Status

This is the initial opening page of the program.

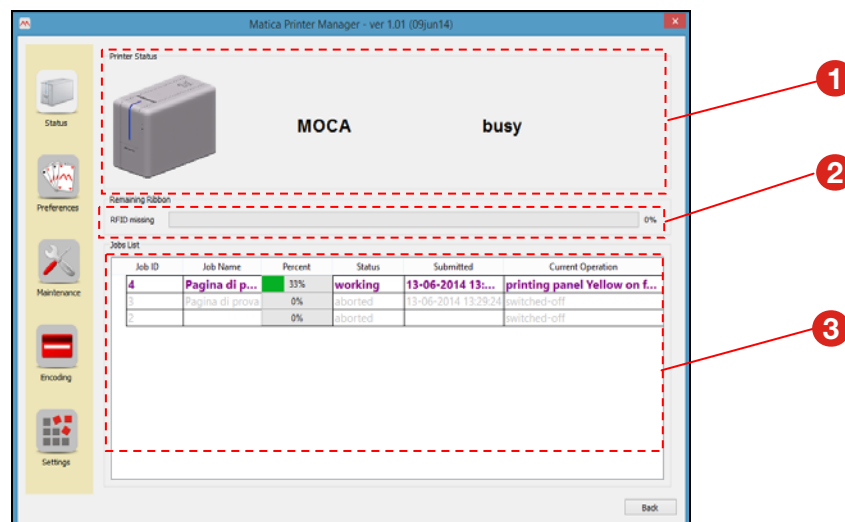

The following information areas are available: **1) Printer Status** – **2) Ribbon Status** – **3) Job List**.

Printer Status Area

The printer status and error or warning messages are displayed in this area. The possible conditions are: Ready, Busy, Offline, Error.

Ribbon Status Area

Ribbon-related information is displayed in this area.

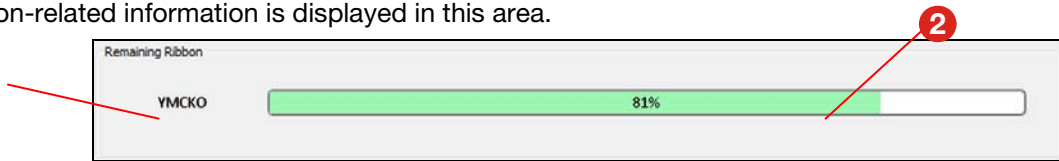

- 1) Type of ribbon installed.
- 2) Remaining ribbon capacity indicator: this indicator shows a percentage of how much ribbon can still be used.

Job Status Area

A job queue is displayed in this area when a printing is underway.

Job ID	Job Name	Percent	Status	Submitted
1	Test Card 1	88%	working	10:21:40
1	Encoding	100%	done	
2	Printing	100%	done	
3	Laminating	57%	working	
2	Test Card 2	66%	working	10:22:30
1	Encoding	100%	done	
2	Printing	80%	working	
3	Laminating	0%	waiting	
3	Test Card 3	19%	working	10:23:50
4	Test Card 4	0%	waiting	10:25:00

Preferences

Open the **Preferences** by clicking on the icon .

This button to run the printer driver user interface program from where Printer Preferences and other printer parameters can be set.

It provides a short-cut to the printer driver program without having to exit the Printer Manager. The first tab displayed by default is the Card tab.

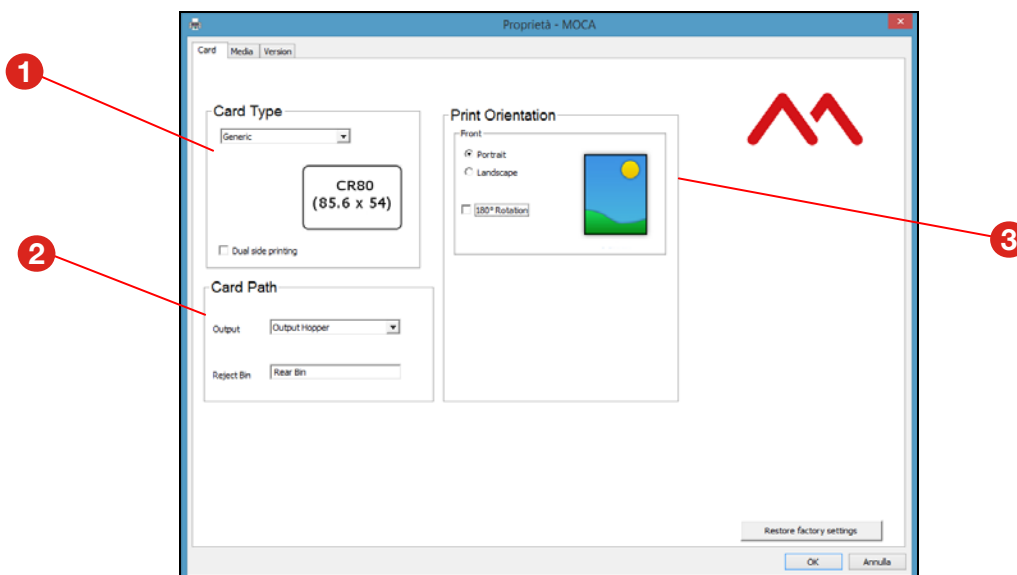

- 1) **Card Type**: makes it possible to set the type of card and front/rear printing.
- 2) **Card Path**: makes it possible to select the output and bin for the card to be printed.
- 3) **Print Orientation**: select the orientation (portrait, landscape, 180° rotation) and the print on both sides.

Click **OK** to store the user settings, click **Restore Default Settings** to clear the user settings and restore the factory default settings.

Maintenance

Open the **Maintenance** by clicking on the icon . From this area you can test the print quality using the test card layouts and launch the printer cleaning routine.

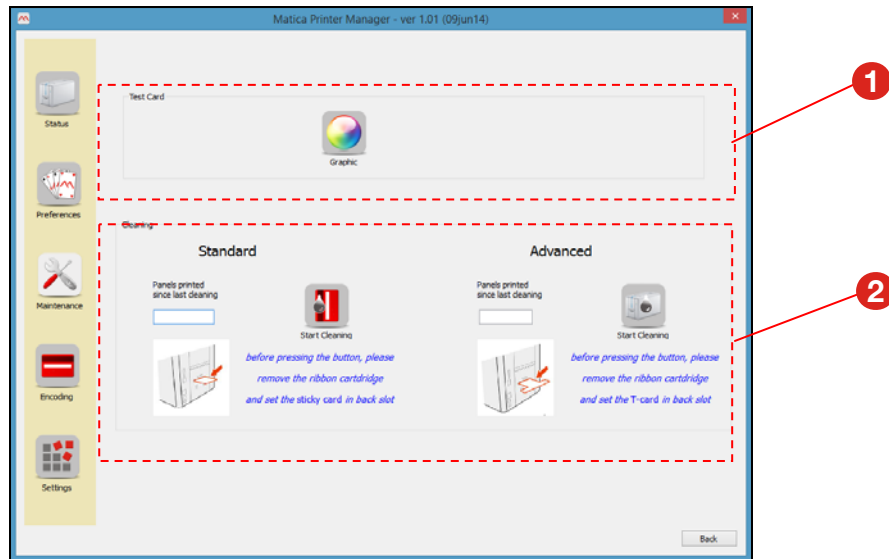

In this environment you can run:

1) Test Card, for printing a test card – **2) Cleaning**, for standard or advanced card cleaning.

Click on **Back** to return to the Status screen.

Encoding (optional)

Open the **Encoding** by clicking on the icon . If available, this feature enables magnetic encoding and the retrieval of the Smart Card ATR number.

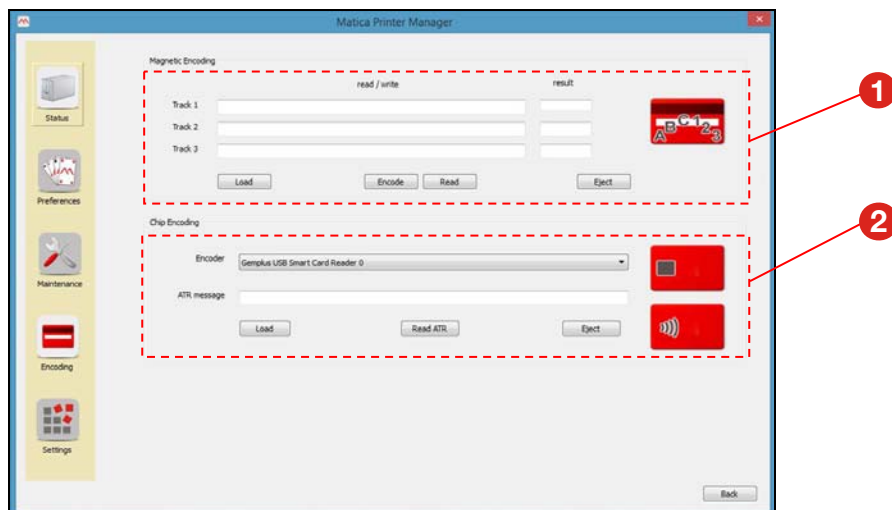

The following can be defined in this area:

1) Magnetic encoding: test the module and single card read/write on the magnetic stripe of the card

2) Chip encoding: test the module and read the ATR of smart cards.

Note: Refer to Chapter “Encoding option” for more information.

Settings

Open the **Settings** by clicking on the icon . Duplex activation, Energy Savings, Firmware Updates and Options can be configured in this area.

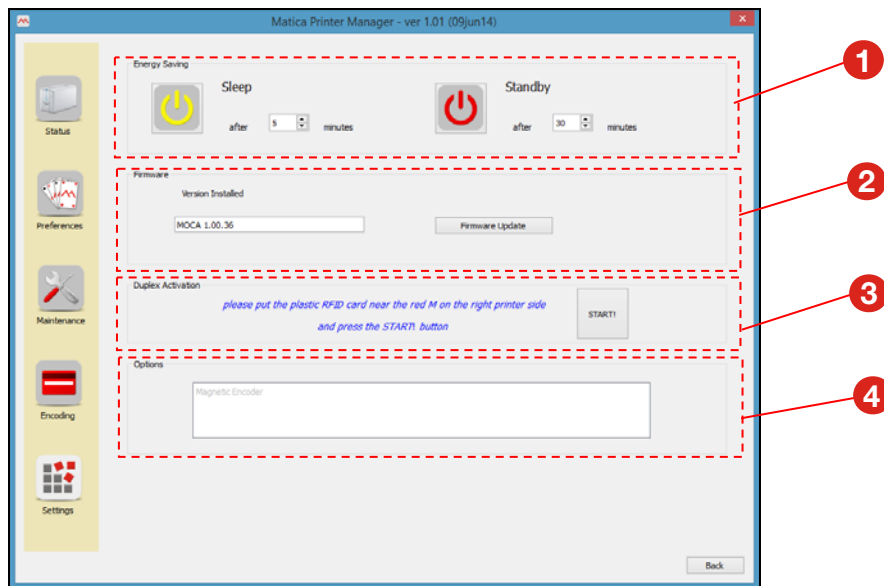

- 1) **Energy saving** parameters.
- 2) **Firmware** Update.
- 3) **Duplex activation** settings.
- 4) **Options** installed on the printer.

Click **Back** to return to the Printer Status screen.

Energy Saving

Set the energy saving features in this area.



Sleep

Selecting or deselecting the Enabled check box enables or disables, respectively, the Sleep feature.

If Sleep is disabled, Standby mode also is disabled, and therefore the sleep time is set to the factory default value of 5 minutes. To set the time field when Sleep is enabled, set the value using the sidebar arrow buttons or enter the value directly. The selectable range is from 1 to 240 minutes, in steps of one minute.

Standby

Selecting or deselecting the Enabled check box enables or disables, respectively, the Standby feature.

Standby mode is active only if Sleep mode is enabled. When Standby is enabled, set the time using the sidebar arrow buttons or enter the time directly. The selectable range is from 1 to 1440 minutes, in steps of one minute.

Note: A time less than or equal to the standby time is not allowed.

Updating the Printer Firmware

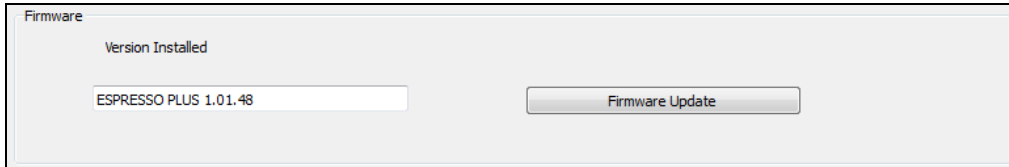

The Version Installed field shows the current version of the printer firmware.

Click **Firmware Update** to launch the Update Firmware wizard.

Duplex activation

Two-sided printing can be enabled in this environment (for more information refer to the documentation provided with the option).

Options

Options Installed: Codes of the options installed.

Printer Status Pop-up

The Printer status pop-up consist of a card window containing several areas that the software compiles in real time every time the pop-up needs to be displayed.

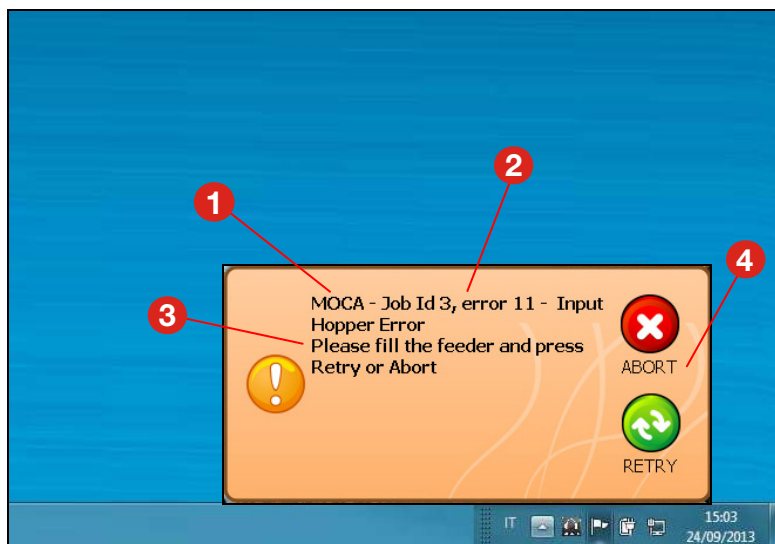

- 1) Printer Name area:** the printer's default name or its name assigned during installation is displayed in this area.
- 2) Status Description area:** the error code or error description is displayed in this area.
- 3) Status Solution Area:** the troubleshooting message related to the error detected and displayed in the Status Description Area, is displayed here.
- 4) Utility Command Bar:** displayed only when the Pop-up is static and user intervention is required. The status error table describes how the utility bar is managed.



- a- **RETRY** : click to resend a print job once an error condition is cleared. Clicking this button causes the pop-up to disappear; if the error is not cleared the pop-up will be displayed again.



- b- **ABORT** : click to remove a print job from the printer spooler.

Printing

Card Printing

Cards are usually printed and encoded by a Printer Application chosen by the User. However, if required, a compatible non-proprietary Application is available as an option for designing and printing cards. Cards can be customized (logo, image and name) by creating graphic images and defining page formats.

The Printer Application recognizes the printer, allowing the User to create fully customized card jobs.

Card Printing Using Word

There are a large number of Windows applications that allow document printing (for example Microsoft Office® suite tools such as MS-Word®, MS-Access®, MS-Excel® and MS-PowerPoint®).

An example is provided below:

Using Microsoft® Word

- 1) Run the MS-Word application. In the Menu bar, click **File** then **Page Setup**.
- 2) In the **Card** tab, select the card Size option followed by the custom format 55x85 mm (default format).
- 3) If using Word 2010/2013: select the **Page Layout** tab. For Size, select Custom format.
- 4) In the **Margins** tab, set all margins to '0' and select Landscape for the Orientation.
- 5) Close the window by clicking **OK**.
- 6) The card can now be customized by adding the various items composing the card:
 - Logotype, illustrations, Identification photo
 - Fixed and variable texts
 - Barcode, etc.

Once the operation is complete, click **File** followed by **Print**.

- 7) Click **Print** or click on the printer icon. Select Matica printer.
- 8) Select **Properties** to customise the print options from this screen:
- 9) Select the **Output** choosing between **Output Hopper** or **Rear Bin**.

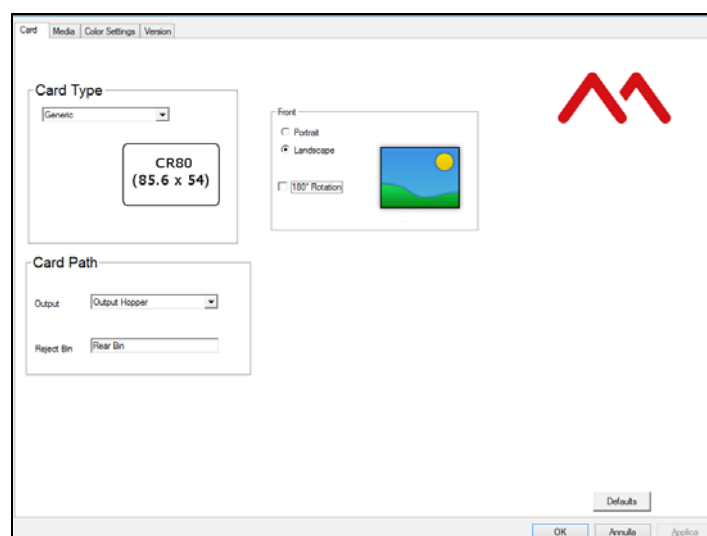

10) Click the **Media** tab to configure specific settings such as:

- Ribbon Identification
- Color Panel Adjustment (brightness, contrast, sharpness)
- Overlay Panel Adjustment
- K Panel /Monochrome Adjustment (greyscale, black text, etc..)

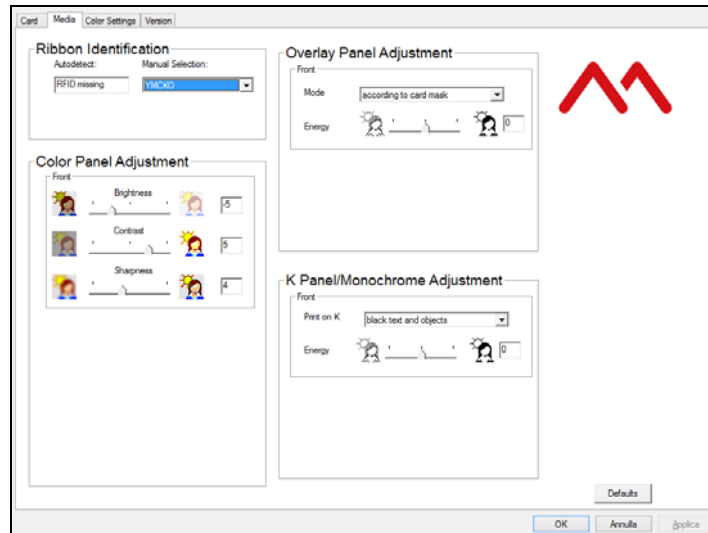

Management of the Overlay panel

This function, available in the print driver, is used to print a card using one of the following overlay functions available:

- **According to card mask** - the overlay function is applied only to previously defined areas
- **Nothing** - no overlay function
- **User bitmap** – used to print a card from a file that contains the same background graphics without having to retransmit the background information in each print file. If used correctly, may improve printing efficiency.

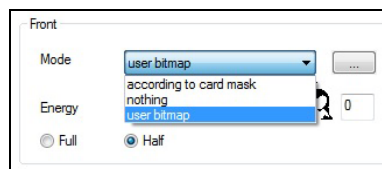

In the case of a Half panel, it is possible to select whether the panel with Overlay is to be applied to the entire card (**Full flag on**) or only to the zone corresponding to the colour half panel (**Half flag on**).

User bitmap type overlay

Selecting the “user bmp” function from the drop-down menu, it is possible to select the areas to which the Overlay is to be applied. To do this, create a file with **bmp** extension and colour depth at 1 bit (e.g. with the Microsoft Paint application) in which the areas in which to apply the Overlay are coloured. Selecting this file from the drop-down menu, the Overlay will be applied to the black areas as indicated in the file selected.

Double-side Printing

- 1) Select **Properties** from print properties to personalise printing options:
- 2) Check the box selection **Dual side printing** for front and back printing.
- 3) Click **OK** to store the settings made and print the card.

Note: Two-sided printing is optional (installation of the Duplex Kit is required).

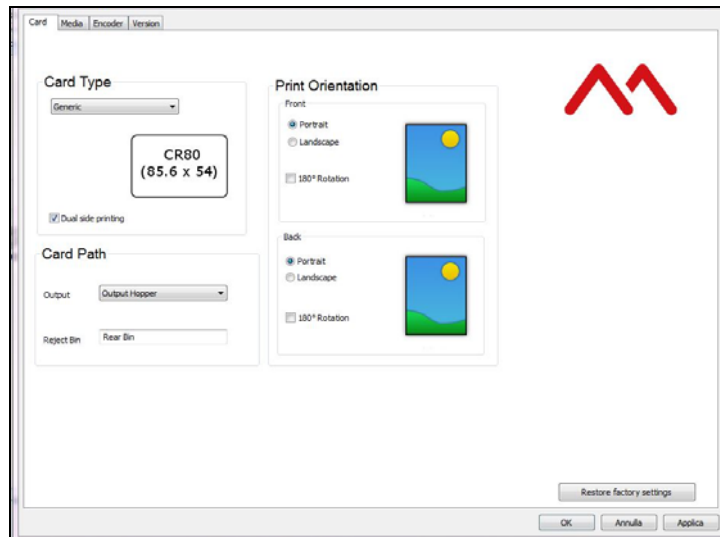

If **Dual-sided** printing was selected, by clicking the **Media** tab of **Printer Preferences** the following parameters for the two sides of the card can be selected independently:

- Color Panel Adjustment (brightness, contrast, sharpness)
- Overlay Panel Adjustment
- K Panel /Monochrome Adjustment (greyscale, black text, etc..)

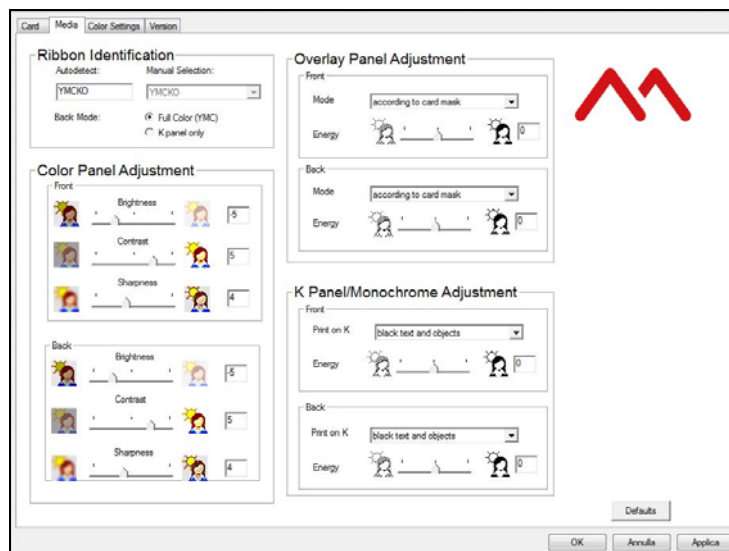

Note: The **Back Mode** button default selection optimizes the consumption of the ribbon installed in the machine. A different setting other than the default can be selected but this means enabling the printer to consume a greater amount of ribbons.

Color Settings

To customize color printing, click Printer Driver Properties and then click the **Printer Driver Preferences** tab.

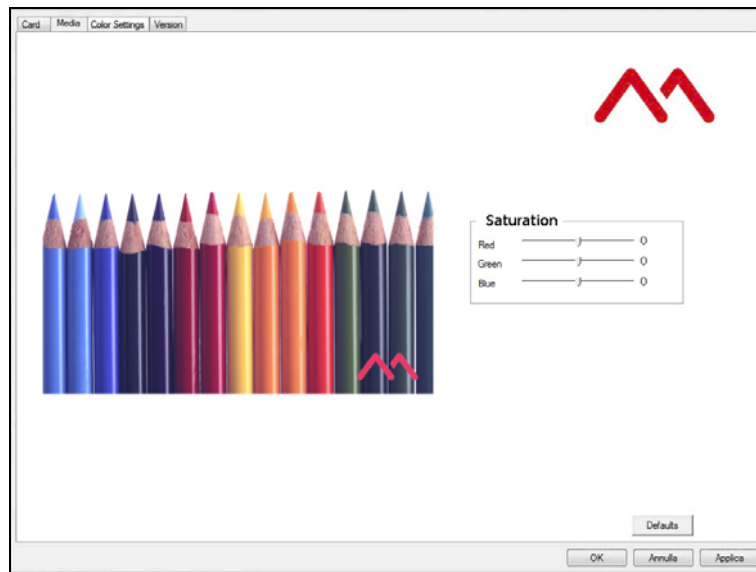

You can modify the saturation of each colour being printed by moving its related cursor.

When the cursors are moved, the image with the coloured pencils illustrates how the settings change.

However, to be sure that the actual result obtained meets your expectations, it is necessary to run a few print tests.

Click **Defaults** to restore the factory default settings.

Printer Maintenance

Printer Routine Cleaning

Four different cleaning processes are implemented in the printers.

Standard Cleaning

Suggested frequency:

- *Color printing: Each time the ribbon is changed*
- *Every 1,200 cards printed.*

Standard cleaning is performed using the specific cleaning card as explained below.

The product has an internal counter that keeps track of the number of cards printed and warns the user when the mandatory cleaning procedure must be performed.

Standard Cleaning Procedure

- 1) Open the printing module compartment cover.
- 2) Remove the ribbon carrier.

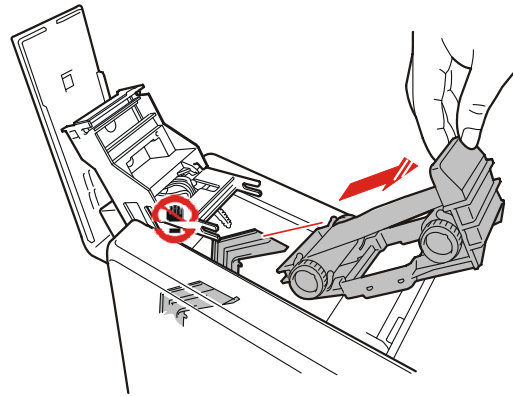
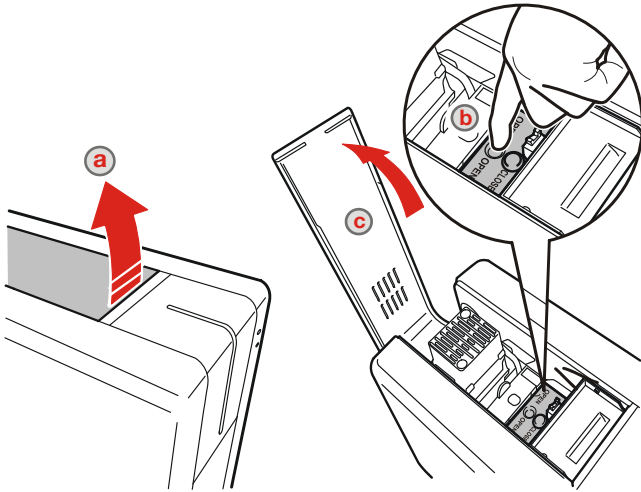

- 3) Close the printing module compartment cover.

- 4) Use the cleaning card CR80 (A) or the extended Card (B). Remove all the protective film.

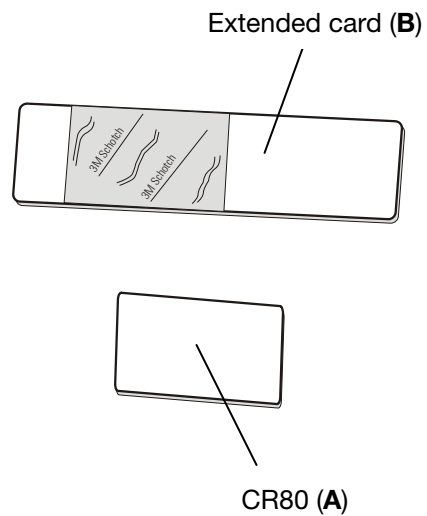
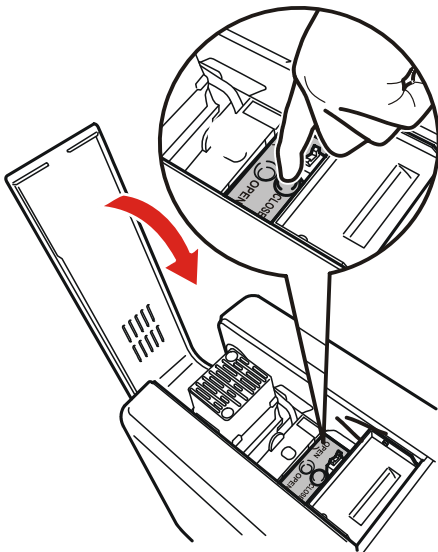

5) Insert the cleaning card (A) in the rear slot of the printer. The adhesive surface should remain at the top.



or insert the extended card (B) in the rear slot of the printer as represented in Figure. The adhesive surface is on both sides.

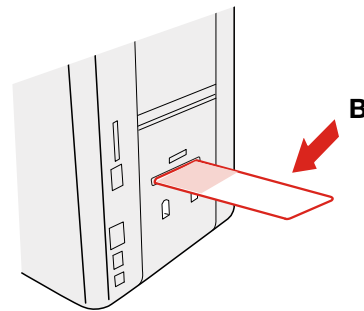
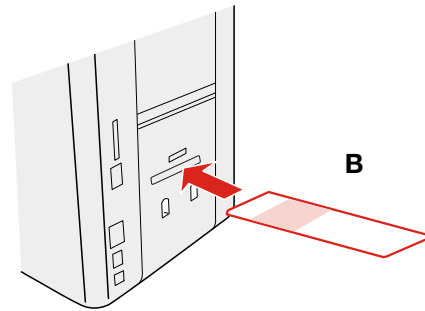

6) Open the **Printer Manager** and click the **Maintenance** button. The Maintenance window is displayed.

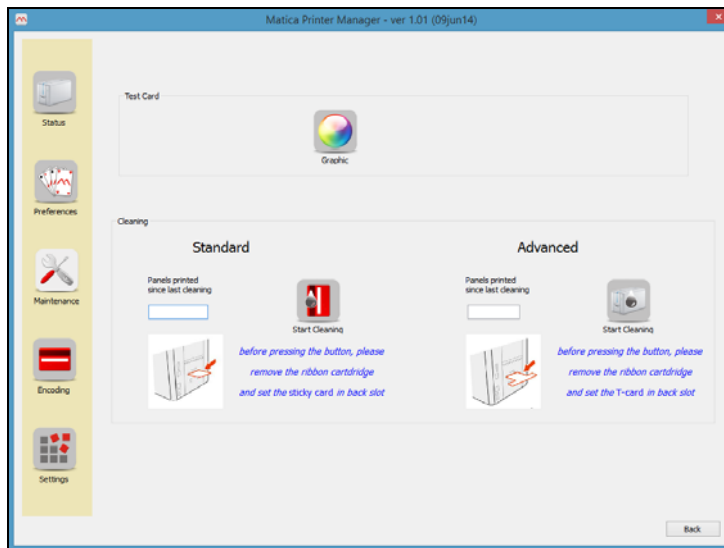

7) The counter indicates the number of cards that have been printed starting from the last cleaning operation performed. Click the **Standard Cleaning button** to start the cleaning procedure. Once the cleaning procedure is completed, the card is ejected from the rear slot and the counter is reset.

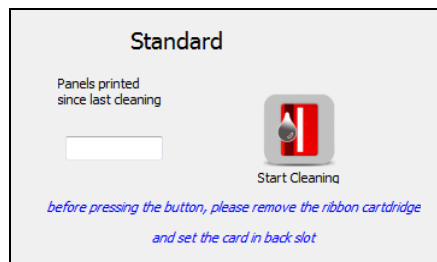

8) Re-insert the support and close the print module compartment. The cleaning procedure has been completed.

Card Path Advanced Cleaning

The card path advanced cleaning procedure is required after performing five Standard cleaning procedures:

- The special (alcohol impregnated) T-card must be used.
- The procedure involves cleaning the card path, removing the dust on the rollers and cleaning the magnetic head.
- The printer has an internal counter that stores the number of Standard cleaning procedures performed, so as to notify when the Advanced Cleaning procedure is required.
- A software-guided procedure will assist in carrying out the cleaning operations.

Advanced Cleaning Procedure

1) Open the printing module compartment covers.

2) Remove the ribbon carrier.

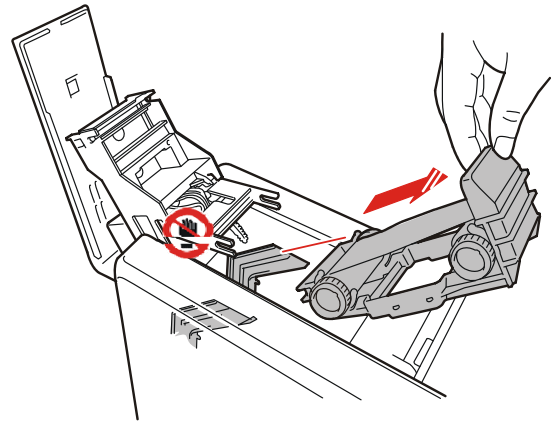
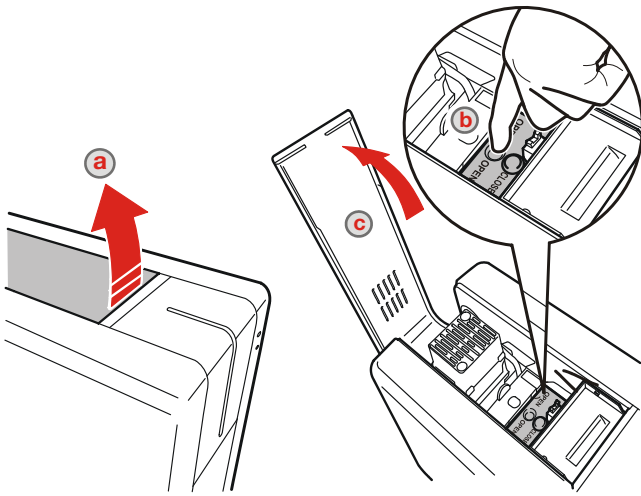

3) Close the printing module compartment covers.

4) Insert the T-card into the rear slot of the printer.

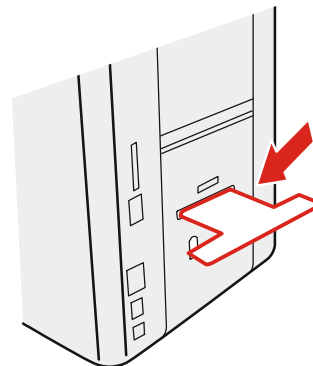
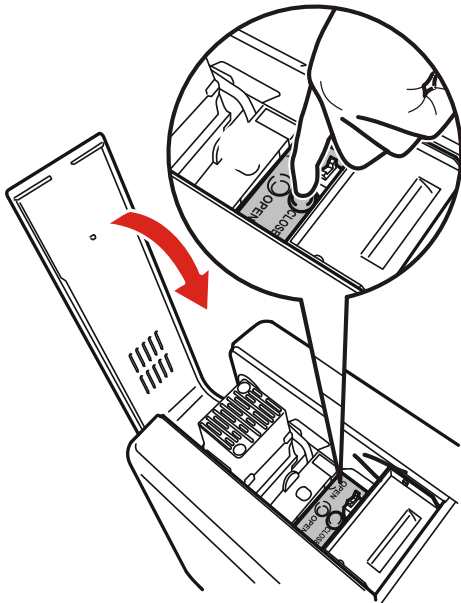

5) Open the **Printer Manager** and click the **Maintenance** button. The Maintenance window is displayed.

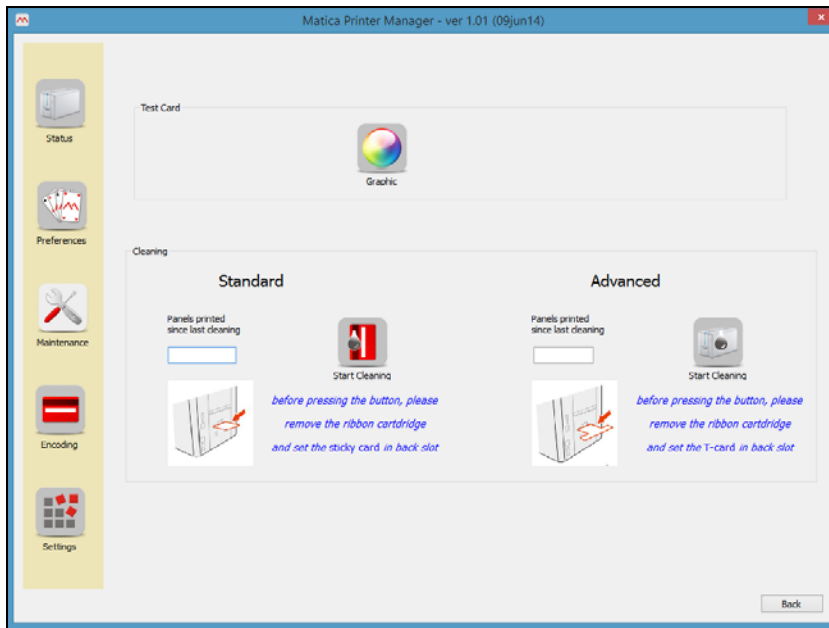

6) The counter indicates the number of cards that have been printed starting from the last cleaning operation performed.
Click the **Advanced Cleaning button** to start the cleaning procedure.
Once the cleaning procedure is completed, the card is ejected from the rear slot and the counter is reset.

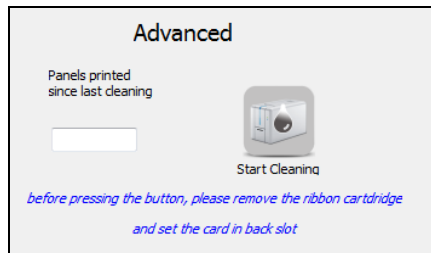

7) Re-insert the support and close the print module compartment. The cleaning procedure has been completed.

Cleaning Roller Advanced Cleaning

It is suggested to perform an advanced cleaning of the cleaning roller when the standard cleaning procedure does not efficiently remove all the dust from the cleaning roller.

Roller Cleaning Procedure

- 1) Unplug the printer from the power supply.
- 2) Open the printing module compartment covers.
- 3) Remove the ribbon carrier.

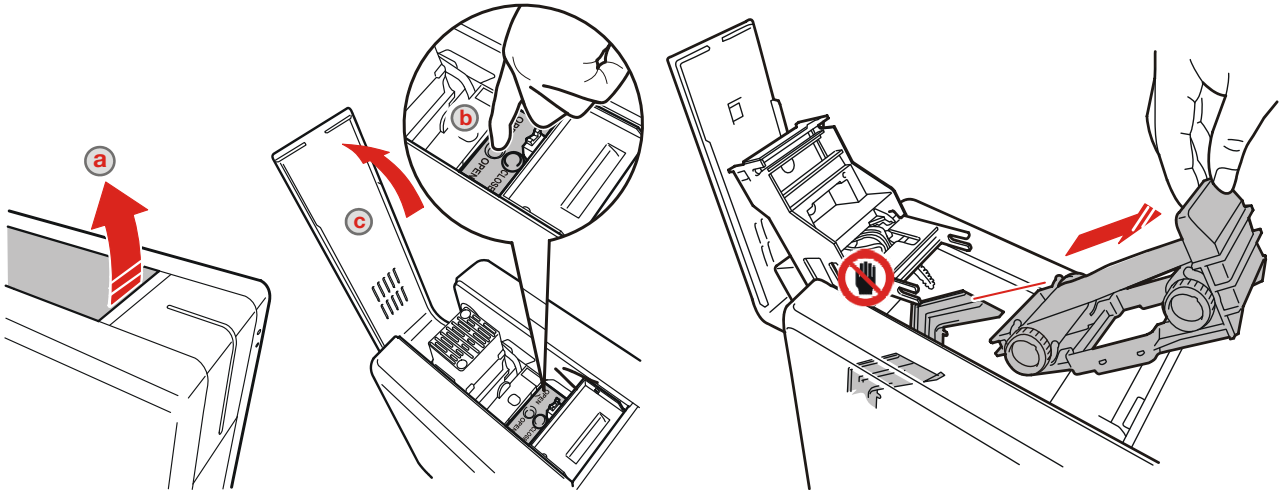

- 4) Identify the roller.
- 5) Remove the roller by extracting it parallel to the printing module and slightly upwards, until hearing a release click.

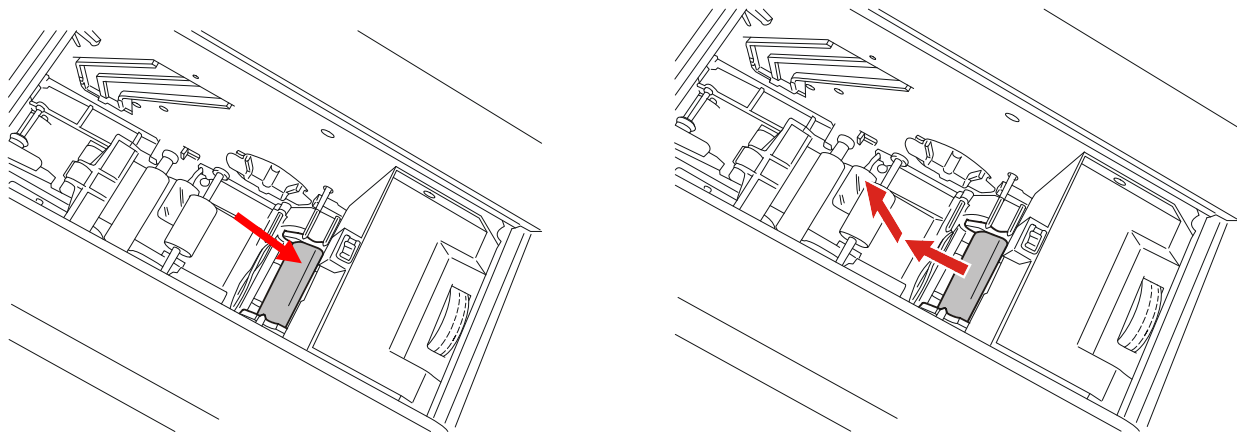

- 6) *Clean the roller using water and dry it.*

- 7) Reinsert the roller, pushing it into its seat, pressing downwards and parallel to the surface of the printing module.

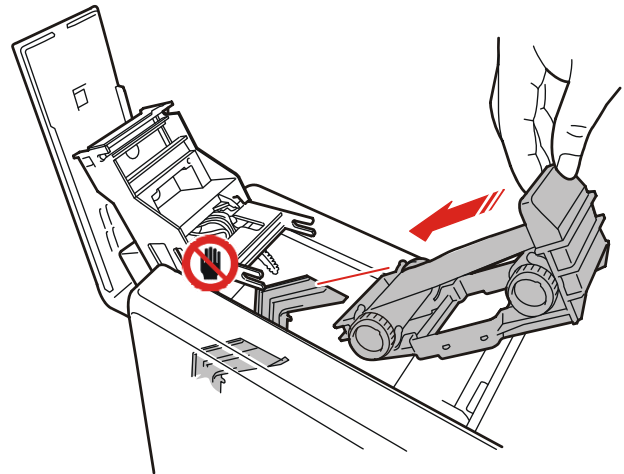
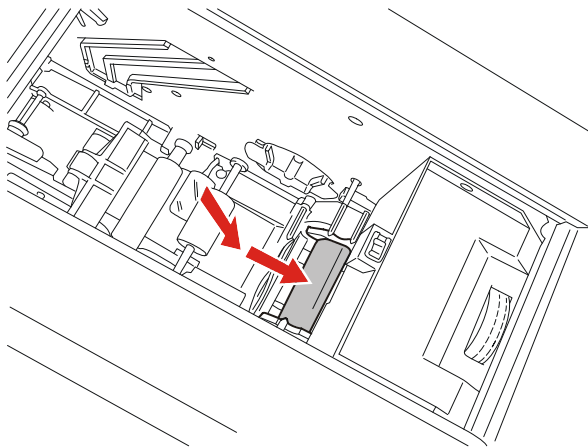

- 8) Re-insert the support and close the print module compartment. The cleaning procedure has been completed.

Printhead Cleaning

It is advisable to clean the printhead when light-coloured or white streaks appear on the printed card in the direction of printing:

- The edge of the printhead must be cleaned using the special impregnated swab or the cleaning pen.
- The edge of the printhead must be cleaned to remove residual ink or dust.

Printhead Cleaning Procedure

- 1) Unplug the printer from the power supply.
- 2) Open the printing module compartment covers.

- 3) Using the cleaning swab that is provided in the Cleaning Kit, clean the printhead by rubbing the swab it in the direction indicated by the arrow in the figure below.

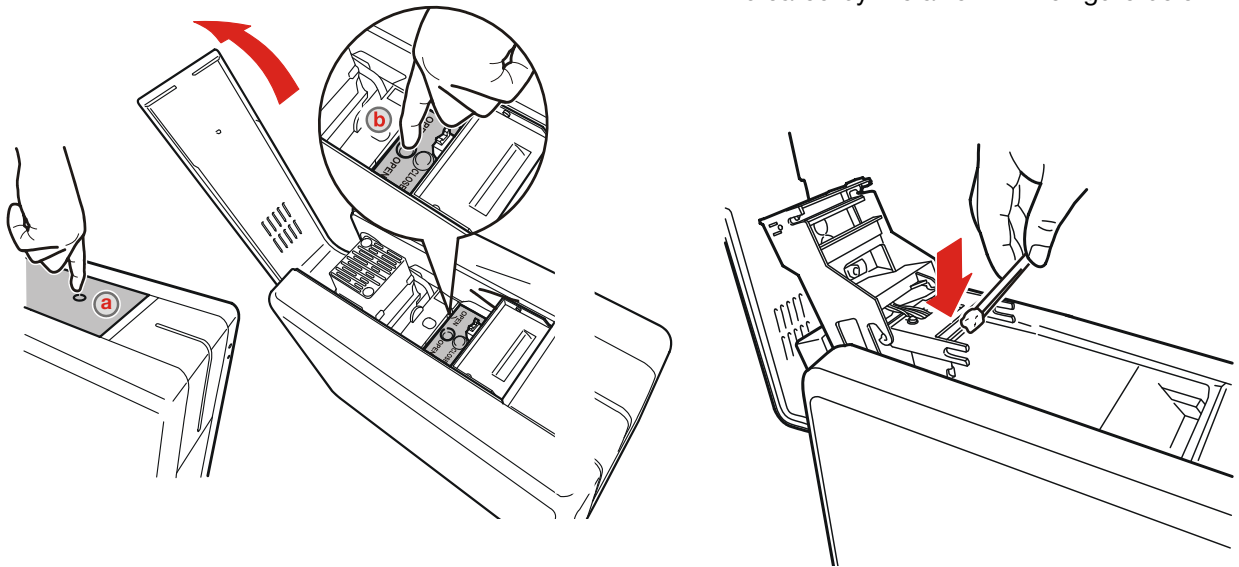

- 4) Re-insert the support and close the print module compartment. The cleaning procedure has been completed.

Printing Test Cards

Test Cards are used to check that the printer is operating correctly and to obtain some important printing parameters.

Open the **Printer Manager** and click the **Maintenance** button. The following screen is displayed.

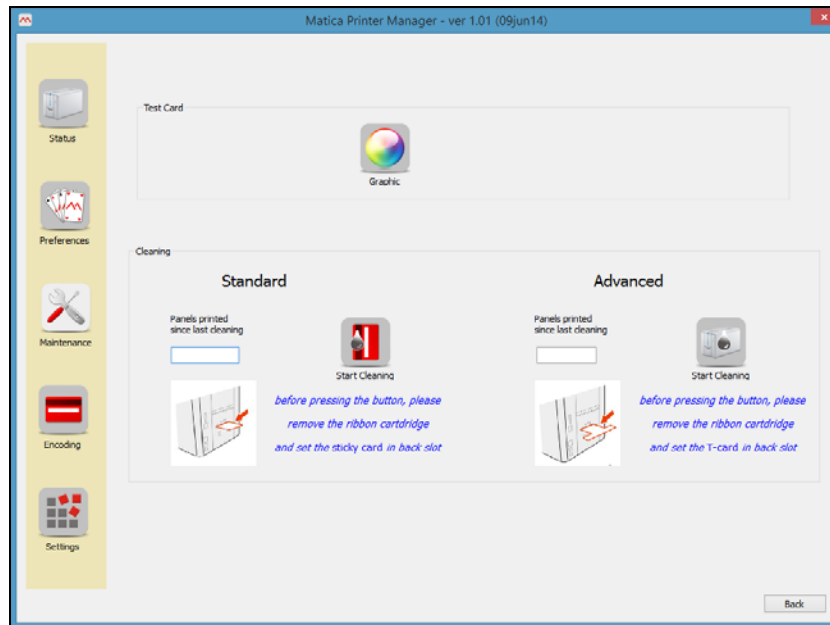

Printing a Text Test Card

In the Test Card area, click the **Text** button to launch the Monochromatic Test Card print quality test. Used mostly when a monochrome ribbon is installed or to test the black panel in a multi-panel ribbon. Printer information is printed on the Text Test Card.

Printing Graphic Test Card

In the Test Card area, click the **Color** button to launch a Graphics Test Card print quality test. It is mainly used when a multi-panel ribbon is installed.

Printing a Dual-Side Test Card

In the Test Card area, click the **Dual Side** button to launch the Dual-Side Test Card print quality test. The button is displayed only when the front-rear printing function has been activated on the printer.

Print head replacement procedure

As the print head is the most important component of the printer, it is advisable to carry out the recommended cleaning procedures in order to guarantee maximum quality at all times and longest possible service life.

However, the print head may become worn and must be replaced after a certain period of time.

Replacement procedure

- 1) Unplug the printer from the power supply.
- 2) Open the printing compartment module cover.
- 3) Remove the print head. Press in the direction indicated by the arrow to loosen the spring and to release this from its housing.

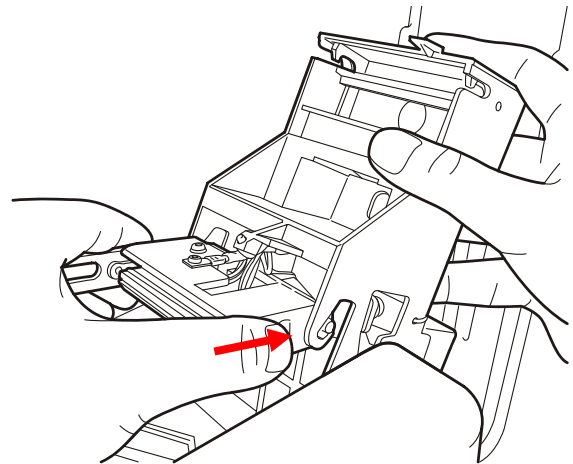
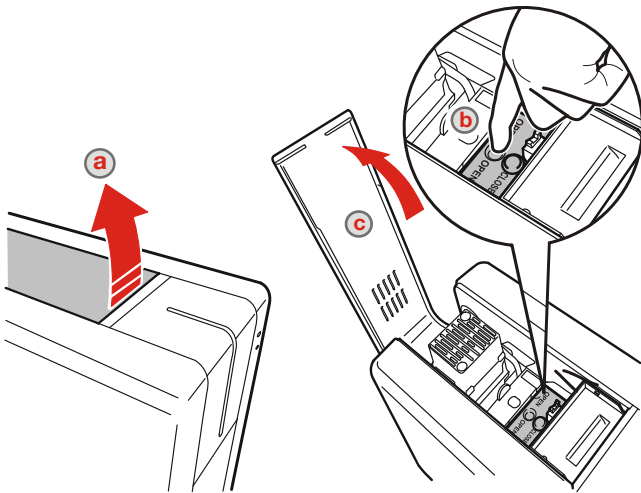

- 4) Remove the earth wire and the connector, connect these to the **new** print head and make a note of the **PH code number**

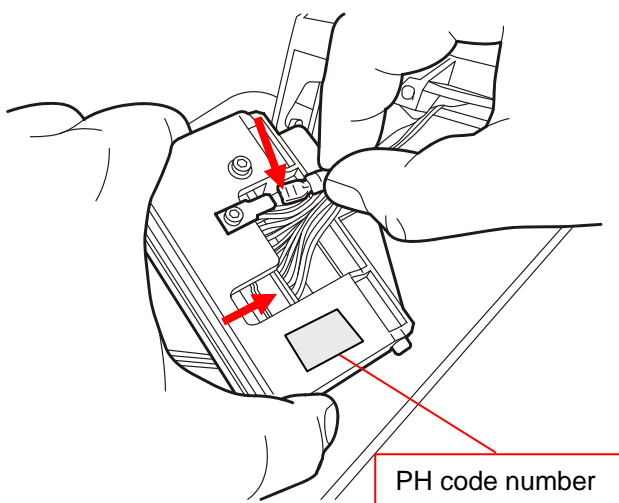

- 5) Insert the new print head. During re-insertion, press with the sphere present in the tip of the print head on the point indicated in the figure and rotate it slightly in order to insert it in its housing.

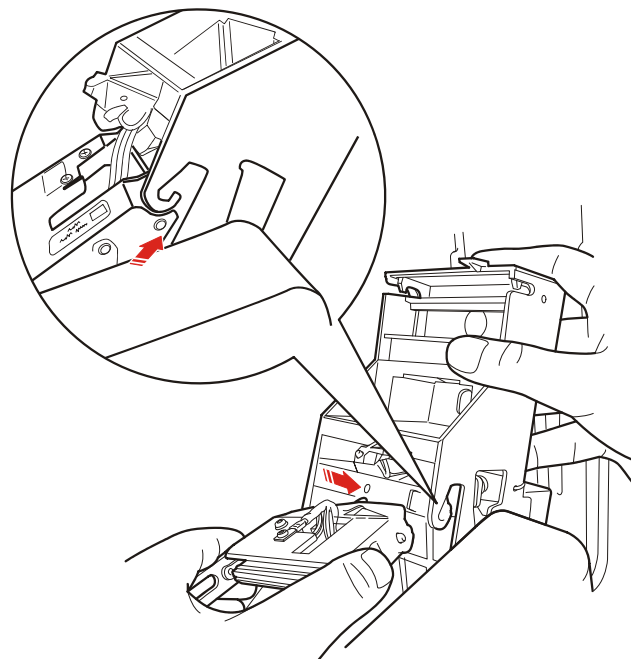

6) Close the printing compartment module cover.

7) Connect the printer to the power supply, switch on and connect it to a computer with the USB cable.

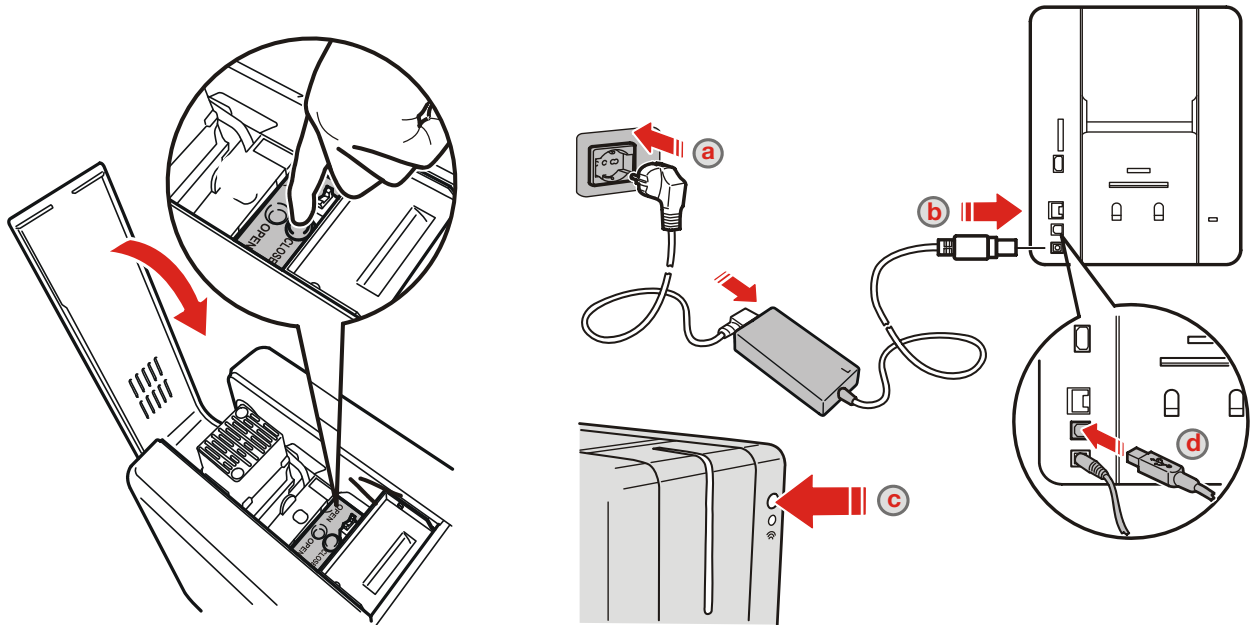

8) On the computer on which the Matica Print Manager program has been installed, select the **Maintenance** environment and press the **“Print Head Replacement”** button. The following screen page is displayed:

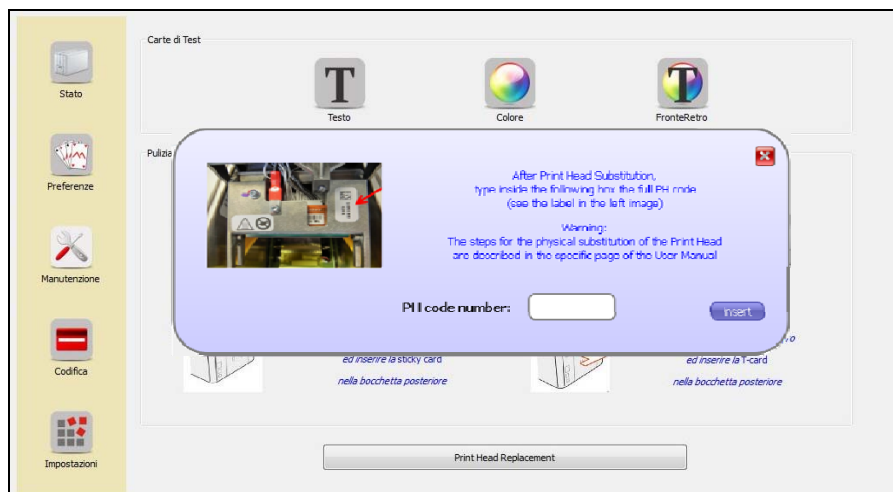

9) Enter the **PH code number** and confirm with the **Insert** button.

10) The print head replacement procedure has been completed; standard cleaning and cleaning of the print head will be requested. Follow the instructions shown on the display.

Encoding Options

Chip Encoding

The Chip Encoder is an optional module for the Espresso products that allows the encoding of chip cards (smart cards).

Available chip encoding modules and related functionalities:

- **CHIP ENCODING STATION COMBO PCTWIN + OMNIKEY**
Allows you to run chip encoding on contact cards (via Chip PCTwin) and on cards with out contacts (via Chip Omnikey) Code **PR000015**
- **CHIP ENCODING STATION CONTACT PCTWIN**
Allows you to run chip encoding on contactless cards only (via Chip PCTwin) Code **PR000024**
- **CHIP ENCODING STATION CONTACT OMNIKEY**
Allows you to run chip encoding on contact cards only (via Chip Omnikey) Code **PR000025**
- **CHIP ENCODING STATION CONTACTLESS OMNIKEY**
Allows you to run only on chip encoding contactless cards (via Chip Omnikey) Code **PR000026**
- **CONTACT STATION AND EXTERNAL ENCODER CONNECTION**
Allows you to run chip encoding using an encoding system off the printer Code **PR000020**
- **CONTACT STATION FOR CHIP ENCODING**
Allows you to run chip encoding with user-selected.
Encoder boards other than those proposed by Matica Code **PR000223**

Install the module according to the instructions contained in the package.

Encoding Test

Warning: Before proceeding with the configuration of the module make sure the printer is turned on and connected to your computer via USB.

Warning: before proceeding with encoding operations, download the driver compatible with the O.S: used in the PC from the site of the encoder board manufacturer.

Test

Open **Printer Manager** and click the **Encoding** button. The following screen is displayed from where it is possible obtain the Smart Card ATR number.

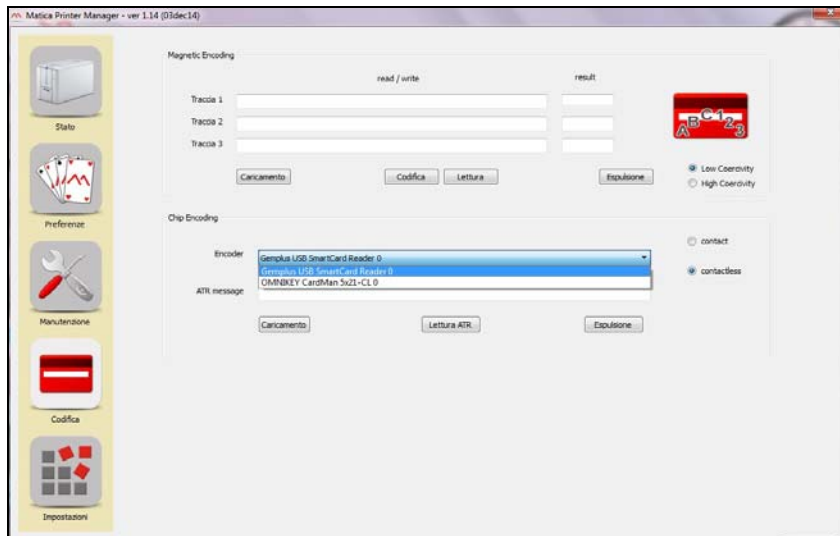

Reading the Chip Encoding

This area provides the ATR number of the contact card. This operation is performed to ensure that the contact encoder is working correctly.

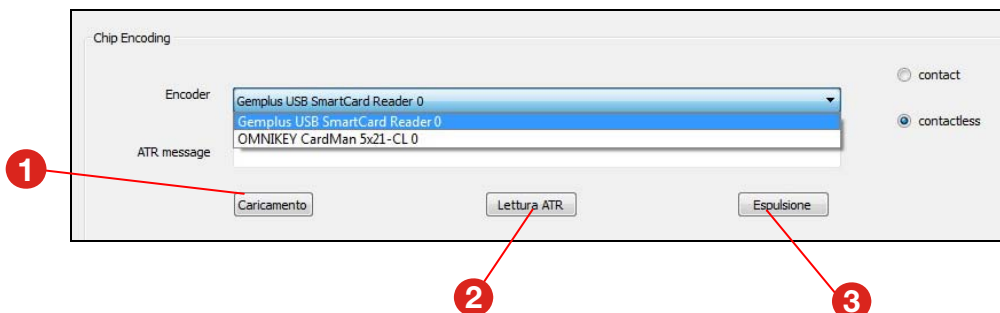

Selecting the Encoder option from the drop-down list, choose the type of encoder you require. If only one encoder is available, this option is not active.

1) Load Button

Click to start a batch job, consisting of:

- Taking the card from the selected or default input (see card path in the printer driver Card tab)
- Moving the card to the contact encoder.

2) Read ATR Button

Click to read the contact card's ATR number.

For the ATR Number to be read, the card must be positioned in the contact encoder by clicking **Load**.

The encoder then reads the card and displays the ATR number in the window. The encoder reads and displays the ATR number until clicking the Eject button, at which point the card is moved from the encoder to the output specified for the card path (see card path in the printer driver Card tab).

3) Eject Button

Click to move the card that has been left inside the printer to the selected or default output. (see card path in the printer driver Card tab).

External Encoding

The machine configured with an external encoder is equipped with a specific 12-pin connector, configured in the following way:

Pin	Name	Description
1	C8	RFU
2	C4	RFU
3	C7	I/O
4	C3	CLOCK
5	C6	VPP
6	C2	RESET
7	C5	GND
8	C1	VCC=5V
9	CDD_NO	CARD DETECT NO
10	CDD_NC	CARD DETECT NC
11	Free	
12	Free	

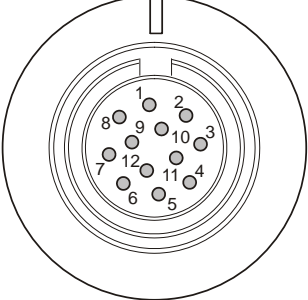

**Binder female socket 12 ways
black connector 720 series
p/n 99 9136 00 12**

A sequence of commands must be sent via the printer interface to insert a card into the printer, position it under the station and establish contact. Sending the command sequence:

- A card is moved automatically from the feeder to the encoding station and stops. The contact station is pushed downward to make contact with the card
- The chip can be programmed via the external coupler.

Magnetic Encoding

The magnetic encoder module is installed in factory and printers with this option are proposed with specific product codes.

The printer with MAG encoder compatible with ISO standards is available and, on request, the MAG printer that complies with JISII regulations for Japan may be available.

Configuration

To print using the Magnetic Encoder, enable these modules on the printer so that the printer driver can use them correctly.

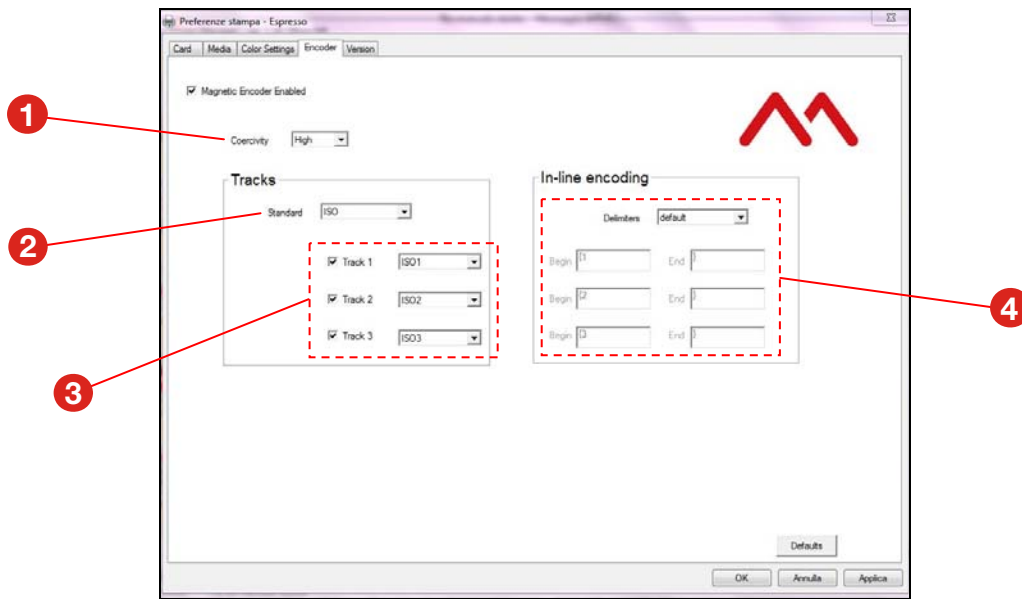

1) Set the **Coercitivity** values from High, Low.

2) Set the "**Standard**" encoding preferences. With this drop down menu is possible to set which standard to use for encoding the cards. These are the possible choices: ISO (Default) - ISO 7811 Standard or JIS-2 - Japanese JISB9561-1979 Standard.

3) **Tracks** (ISO Standard), With these commands, for every single track, is possible enable / disable the track and make the ISO Standard choice.

Track 1, Track2, Track 3: with the selection boxes is possible enable/disable the tracks, with the drop down box is possible choose the standard ISO. The possible choices of Standard ISO in the drop down menu are:

Standard	Track 1	Track 2	Track 3
ISO1	DEFAULT		
ISO2		DEFAULT	
ISO3			DEFAULT

Tracks (JIS-2 Standard): If the JIS-2 standard is choose appear only the track 1 and in the drop down menu is possible only chose the JIS-2 standard. The possible choices of JIS-2 standard in the drop down menu are:

Standard	Track 1
JIS-2	DEFAULT

4) **Mag strip start/end sentinels:** with these command is possible to set the "Special Character Strings" used for the in-line magnetic encoding. These special characters are placed at the beginning and end of the characters that we want to write in the magnetic fields, for more details please refer to the rule ISO7811. Every Start and end sentinel must have the possibility to manage until of 3 characters each. In the drop down menu there are two type of choices:

- **Default:** the strip start/end sentinels Characters are the Standard DCP and they are not editable.
- **Personalized:** the strip start/end sentinels Characters are editable by the user.

In the "begin" and "end" boxes is possible display or set the specials characters. Every row correspond to a track. For each track, you can use up to a maximum of three characters, always followed by the track number as follows:

track 1: start= -%1 end=?
track 2: start= -%2 end=?
track 3: start= -%3 end=?

Test and Encoding

The magnetic card is read and written in the magnetic encoding area.

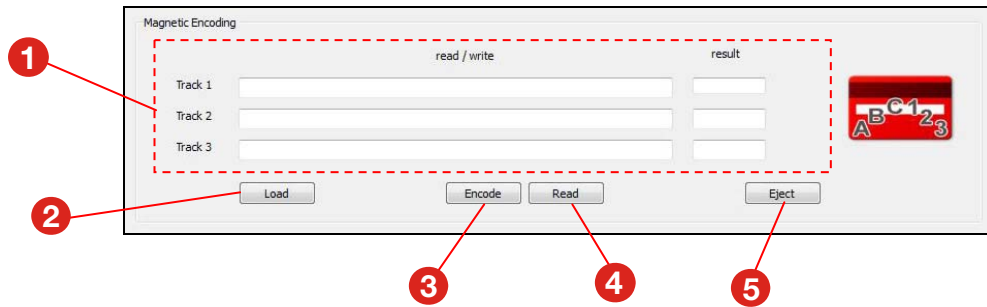

- 1) The Track Area contains the fields (ISO Standard or JIS-II Standard) where the magnetic tracks can be read or written.

Printer Driver Track Status	Track Label	Track Window	Result Box
Enabled	Black	Active (inside, the text displayed in grey shows how the track is set for the printer driver)	Active (empty)
Disabled	Grey light	Not Active, the background is slightly grey (inside, the text displayed in light grey shows how the track is set for the printer driver)	Not Active (empty)

When the read mode is selected, the characters read are displayed in the Read/Write window. When the write mode is selected the characters to be encoded are written in this window.

In the write window, certain checks have to be performed on the characters typed. Characters have to be compatible with the ISO or JIS-II standard chosen for the printer driver, otherwise an error message is displayed.

2) Load Button



Click to start a batch job, consisting of:

- Taking the card from the selected or default input (see card path in the printer driver Card tab)
- Moving the card to the magnetic encoding area.

3) Encode button

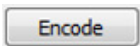

Click to encode a magnetic card.

To encode the card, it must firstly be positioned in the magnetic encoder by clicking **Load**.

- Card encoding: for the enabled tracks, reads the characters written in the track window and encodes them.
- The results window displays whether the operation was executed correctly or not.
- Upon completion of the card writing, the card remains in the magnetic encoding area until clicking **Eject**, at which point the card is then ejected to the specified card path.
- If an error occurs during encoding, the card is sent to the Reject bin.

4) Read Button

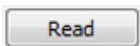

Click to read a magnetic card.

To read the card, it must firstly be positioned in the magnetic encoder by clicking **Load**.

- For enabled Tracks, it displays the value read in the track windows. In the results window, it indicates whether the operation was executed correctly or not.
- Upon completion of the card reading, the card remains in the magnetic encoding area until clicking **Eject**, at which point the card is then ejected to the specified card path.

5) Eject Button

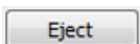

Click to move the card that has been left inside the printer to the selected or default output (see card path in the printer driver Card tab).

Troubleshooting

Printer does not power on

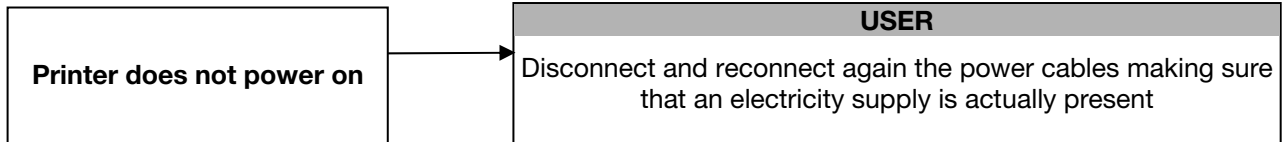

Printer has printing problems

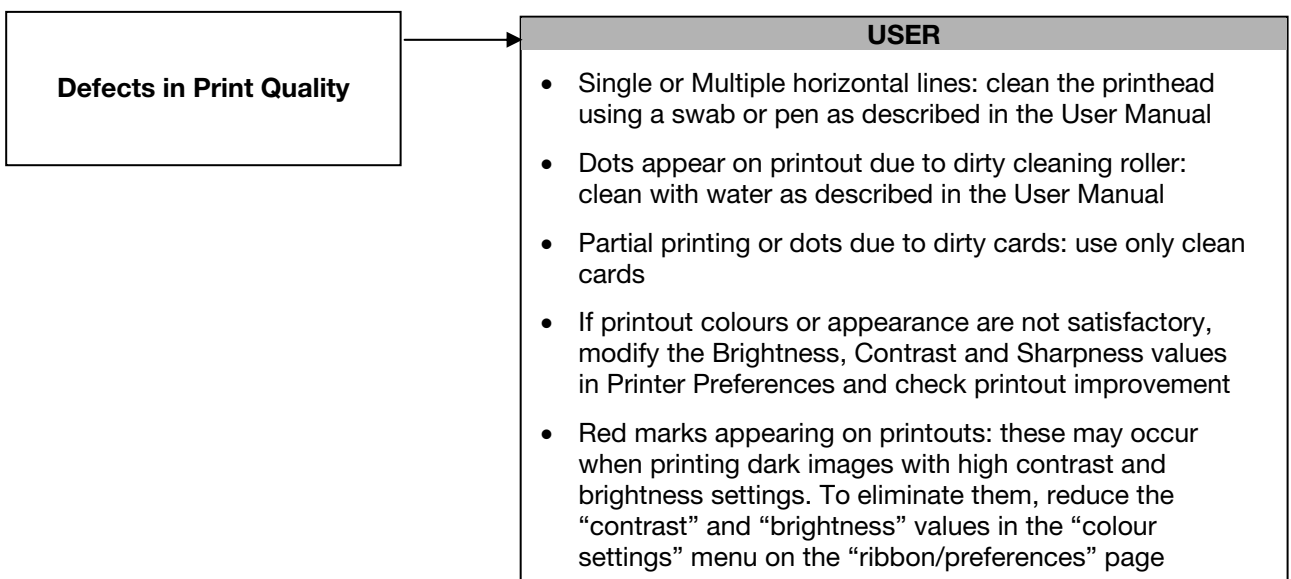
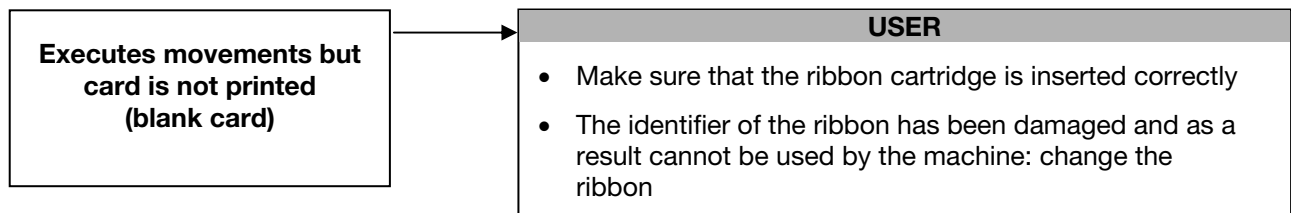
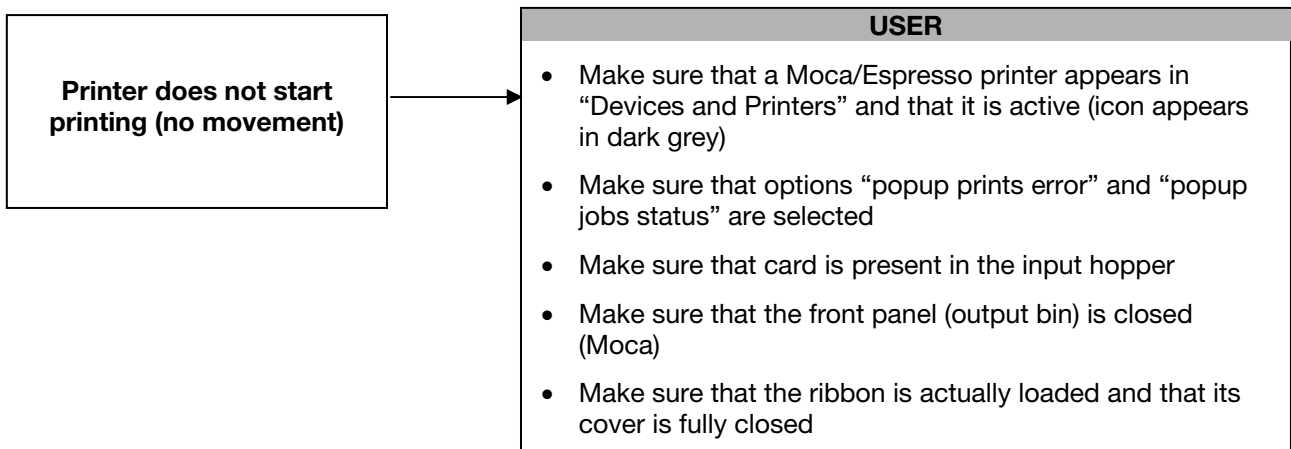

Printer takes up the card but remains blocked

USER

- The card thickness setting does not correspond with that of the card being used: set the correct value, remove the card, then switch the printer off and on again.
- If you are using non-original ribbon, check that the type of ribbon set for the driver corresponds with the one actually being used
- Flip Over not in position: switch off the machine, remove by hand any card left in the flip over, then switch the printer on again
- The weight of the input hopper does not rest on the card in the tray or is missing. Free the weight or introduce it
- Check that the cleaning roller is not out of place. If it is, switch off the machine, put the roller back into position and switch the machine on again.
- Check that no ribbon fragments are present in the card path. If there are, switch the machine off and remove them, then switch the machine on again
- Check that no card is present in the path. If there is, switch the machine off, remove the card, then switch the machine on again

Printer has problem with ribbon

If the ribbon has tears or locks with error 14

USER

- lower the “contrast” and “brightness” values in the “colour settings” menu on the “Media/preferences” tab

Chip Encoding problems

Difficulties or failures in the code reading ATR



USER

- Open the “Devices and Printer” window and select the “USB smart card reader” device
- Select the “Hardware” “Properties” of the device, then go to the “Power Management” tab
- Remove the flag on the line “allow the computer to turn off the device to save power”

Software problems

The Printer Manager is closed and you can not dialogue with the printer

USER

- Open the menu or window applications (depending on the operating system by clicking on the icon  or 
- Run the "Matica Printer Manager" from the program group "Matica> DCP"

Ribbons

The following Matica ribbons can be used:

Ribbon Type	Code to order
Monochrome BLACK: 2000 prints	PR000034
YMCKO : 200 prints	PR000032
YMCKO : 200 prints standard	PR000234
YMCKO : 250 prints - <i>NOT available for MOCA</i>	PR000031
YMCKO : 250 prints standard - <i>NOT available for MOCA</i>	PR000233
Color 1/2 YMCKO : 400 prints	PR000166
Color 1/2 YMCKO : 400 prints standard	PR000235
YMCKOK: 200 prints	PR000033
Monochrome KO: 600 prints	PR000165
Monochrome RED: 1.000 prints	PR000098
Monochrome BLUE: 1.000 prints	PR000100
Monochrome GREEN: 1.000 prints	PR000099
Monochrome WHITE: 1.000 prints	PR000101
Monochrome SILVER: 500 prints	PR000162
Monochrome GOLD: 500 prints	PR000163

Each Matica ribbon has an RFID tag with ribbon identification data that allows the printer to configure all the counting and optimization parameters and procedures.

It is strongly suggested to exclusively use original Matica ribbons. The use of non-original accessories could damage the product and therefore void the factory warranty.

Cleaning Kits

The following Cleaning Kits can be used:

Cleaning kits	Description	Code
REGULAR CLEANING KIT	Regular cleaning kit	PR000196
SERVICE CLEANING KIT	Service cleaning kit	PR000197
SWABS KIT x 50	Swabs kit x 50	PR000203
CLEANING PEN KIT x 12	Cleaning pen kit x 12	PR000204
EXT. CLEANING CARDS KIT x 100	Ext. Cleaning cards kit x 100	PR000205
T-CARD KIT x10	T-card kit x10	PR000207
REFURBISHING STRIP KIT x6	Refurbishing strip kit x6	PR000251

Technical Characteristics

- Single-side or dual-side (*) printing module
- Edge-to-edge printing
- Color dye sublimation and monochrome thermal transfer
- 300 dpi printhead (11,81 dots/mm)
- Up to 128MB of RAM
- Drop-in ribbon carrier
- The user-friendly Printer Driver and Printer Manager application facilitate access to and use of all printer functions.

Card Management

- 100 card capacity in automatic input Hopper (0.76 mm – 30 mil)
- 30 or 80 (*) card capacity in output Hopper (0.76 mm – 30 mil)
- Exception card manual feeder (*)
- Rear bin (*)
- Card types: PVC and composite PVC cards, PET cards, ABS cards (*)
- Card thickness: 0.25 to 1.25 mm (10 to 50 mil)
- Card format: ISO CR80 - ISO 7810 (53,98 mm x 85,60 mm)

Ribbons

- Automatic detection and parameter setting
- Smart Ribbon level memory and management
- Smart Ribbon optimization in monochrome printing
- Available ribbon: please refer to Matica website: www.maticatech.com

Print Speed

- Single-side Monochrome: up to 850 cph (*)
 - Single-side YMCKO: up to 260 cph (*)
 - Dual-side YMCKO-K: up to 160 cph (*)
- (*) In accordance with the document to be printed and print settings selected

Encoding

Magnetic encoder (read/write) 3-track HiCo/LoCo ISO 7811 and JIS II (On request)

- Smart card contact station ISO 7816-1, -2 (excluding Appendix B), -3, -4
- Contact/Contactless encoders compatible with std Cards MIFARE®, MIFARE DESFire® iCLASS® ICODE, ISO 14443 A&B, ISO 15693 and ISO 7816

Software

- Printer driver
- Printer Manager
- Automatic Installer
- Compatible with Windows: W7 32/64 bit, W8.x 32/64 bit, Win10 32/64 bit

Security

- Slot for Kensington® lock

Power Supply

- Auto-switching external power supply unit with interchangeable power cords
- Input 100-240 Volts AC, 50-60 Hz, 1.5 A
- Output 24 Volts DC, 3.0 A

Dimensions and Weight

- Dimensions (H x W x L): 253 x 200 x 395 mm
- Weight: 6.6 kg
- Packaged printer: 300 x 480 x 450 mm weight: 9.1 kg

Quality Standards

- CE, UL, CQC
- Standby mode and reduced power consumption
- Sound pressure less than 48 dB (A) in operation mode (ISO 7779)
- Min/max operating temperature: 15° / 30 °C (59° / 86 °F)
- Humidity: 20% to 65% non-condensing
- Min/max storage temperature: -5° / +70 °C (23° / 158 °F)
- Storage humidity: 20% to 70% non-condensing

() Only in some models/options*

DECLARATION OF CONFORMITY (according to ISO/IEC 17050)

Manufacturer: Matica Technologies AG
Address: Via Salvo D'Acquisto, 8
Turate (CO) - Italy
Year of CE marking: 2014
Equipment category: Information Technology Equipment
Product type: Card Printer
Models: ESPRESSO, MOCA, S3100 XXXXX (X = A-Z, 0-9 or BLANK)

The undersigned hereby declares, on behalf of Matica Technologies AG, that the above-referenced product, to which this declaration relates, complies with the following council directives and harmonized standards.

Council Directives: 1999/5/EC relating to radio and telecommunications terminal equipments
2006/95/EC Low Voltage Directive
2004/108/EC EMC Directive
2011/65/UE ROHS Directive

Harmonized Standards: EN 60950-1:2006 + A11:2009 + A1:2010 + A12:2011
Information technology equipment - Safety - Part 1: General requirements
EN 55022:2010
Information technology equipment- Radio disturbance characteristics- Limits and methods of measurement
EN 55024:1998 + A1:2001 + A2:2003
Information technology equipment - Immunity characteristics - Limits and methods of measurement
EN 61000-3-2:2006 + A1:2009 + A2:2009
Electromagnetic compatibility (EMC) - Part 3: Limits - Section 2: Limits for harmonic current emissions (equipment input current ≤16 A per phase)
EN 61000-3-3:2013
Electromagnetic compatibility (EMC). Part 3: Limits. Section 3: Limitation of voltage changes, voltage fluctuations and flicker in public low-voltage supply systems, for equipment with rated current ≤ 16 A per phase and not subject to conditional connection

Turate (CO), 30.06.2016

Matica Technologies AG

Francesco Ciruolo
Quality and Certification Manager



Product Code: CM00000154en revision F